

Reliable
& Smart™

CSD7 intelligent Series

High Performance & Powerful Servo Drives for General Purpose



EtherCAT®
Conformance tested

Provide two Kinds of Models
EtherCAT Network type
Pulse/Analog command type

RS Reliable & Smart
Automation

CSD7 Series

CSD7 Series is the Servo Drive that has been developed based on the technical skills through 30 years' experience, and represents Korean servo drive. It provides smaller, stronger and more comfortable functions for our customers' systems.



Reliable & Smart · Global brand with the highest quality and performance.

1. Offering improved basic functions

- Enhanced Velocity Bandwidth : Up to 2kHz
- H/W based current controller with minimized delay and enhanced current detection circuit.
- Real Time Vibration Suppression Function (Adaptive Notch Filter)
- 3rd Party Linear motor support
- Offering index function in standard model
- Supporting 2 channels of high-speed Registration input

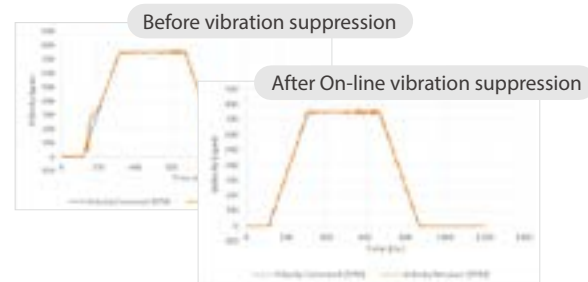

2. Provide high resolution motor with 23bit Encoder

- CSD7 Series support a 23bit Encoder, so its motion profile is high-resolution and smooth with fast position settling time. Vibration/noise has been improved as well for system stability.

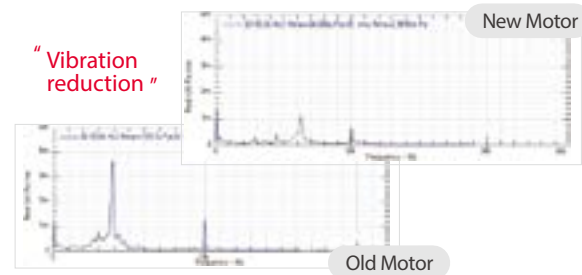

3. A design considering safety and environment

- CSD7 Series obtains safety standards such as STO(Safe Torque Off), CE, NRTL/C, etc to take into the customer's safety. Also, it was created into the product that considered the environment of RoHS application.
- The Safe Torque Off (STO) function of the CSD7 series is a reliable safety feature that allows the motor to stop in any hazardous situation



Smallest footprint, built-in Power, Servo Drive with high precision control

CSD7 Series

- EtherCAT Network type
- Pulse/Analog command type



4. Gain Tuning-less Function

- Detect the load status automatically for optimal control
- Real-time inertia estimation, resonance suppression
- Available for reducing the installation time
- Available for reducing maintenance cost

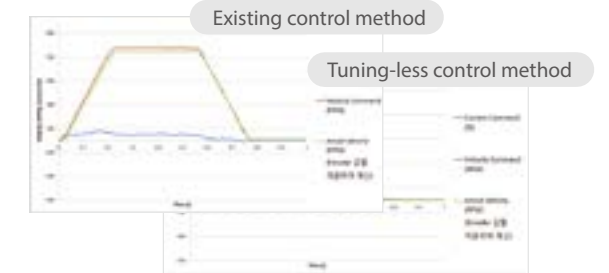

5. Linear motor support without serial converter

- All models of CSD7 series can drive linear motors made by any manufacturer. Please use the linear scale of the following specification.
 - BiSS type linear scale
 - Absolute type without battery
 - A,B Pulse type linear scale
 - Incremental type
 - Pulse input frequency under 15MHz
 - Utilize serial converter in case the input frequency is above 15MHz
 - Serial converter is required for the servo drive higher than 2.5KW

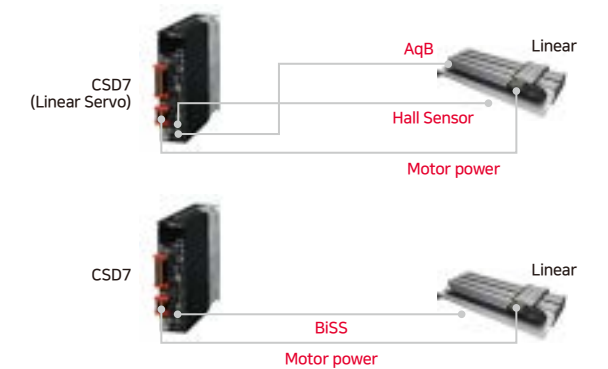

6. More comfortable and refined RSWare

- It now fits for precise tuning with improved oscilloscope function, easy to verify control status, and quick to analyze system. It is now able to run Network products and Pulse/Analog products on the same program.

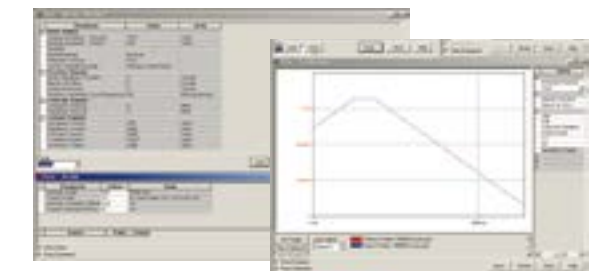

7. Supports close installation between products

- Minimizes Installation Space through Reduced Product Size and Zero Stacking Installation Capability.
- Supports Base Mounting and Rack Mounting.
- Removable Locking Type Connectors
- Provides Two Frame Ground Points for Easy Wiring.

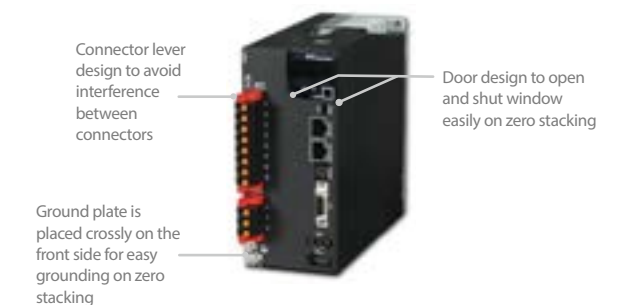



Reliable & Smart · Global brand with the highest quality and performance.

8. Fully Closed Loop Control

- It is now possible to reduce mechanical position error because rotary motor is used for speed/torque control and linear scale is used for position control. (Not supported in CSD7 Linear Servo)

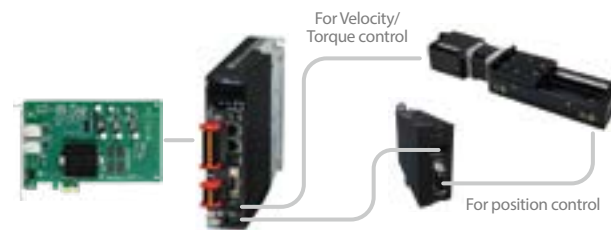

9. Index function (Pulse/Analog command type)

- Through a simple programming, you can configure the system even without expensive controller. For example, it is able to operate the servo drive by choosing several I/Os or serial communication. Also it can implement cost effective system with low cost.
 - Trapezoid motion profile
 - Control with Absolute position, Relative position
 - 128 Point Index
 - Support 11 Homing function
 - 32 axis controls are available through the Modbus communication

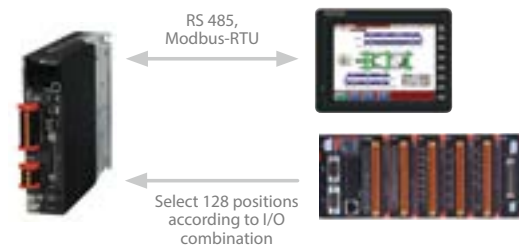

10. EtherNet-based real time motion network

- Support application of EtherCAT CoE communication system and CiA 402 drive profile functions.
 - Enable to connect with the host controller which support EtherCAT CoE, CiA 402 Profile
 - Real-time motion control applied to the communication speed of 100Mbps
 - Apply RJ45 type of connector, use of STP cable which is higher than CAT5(Category 5), Up to 100m between nodes



EtherCAT CSD7

CSD7 Series Product Composition

There are two types of CSD7 series. (Pulse/Analog model, EtherCAT Network model)

■ Pulse/Analog model



■ EtherCAT Network model



EtherNet-based real time motion control

You can build a real time EtherNet-based system at a lowest cost using various EtherCAT products, so that we offer EtherCAT solution together with MMC-EtherCAT Series, PC-based master. Choose from a wide range of choices not only including Pulse/Analog servo drive, but also networks.

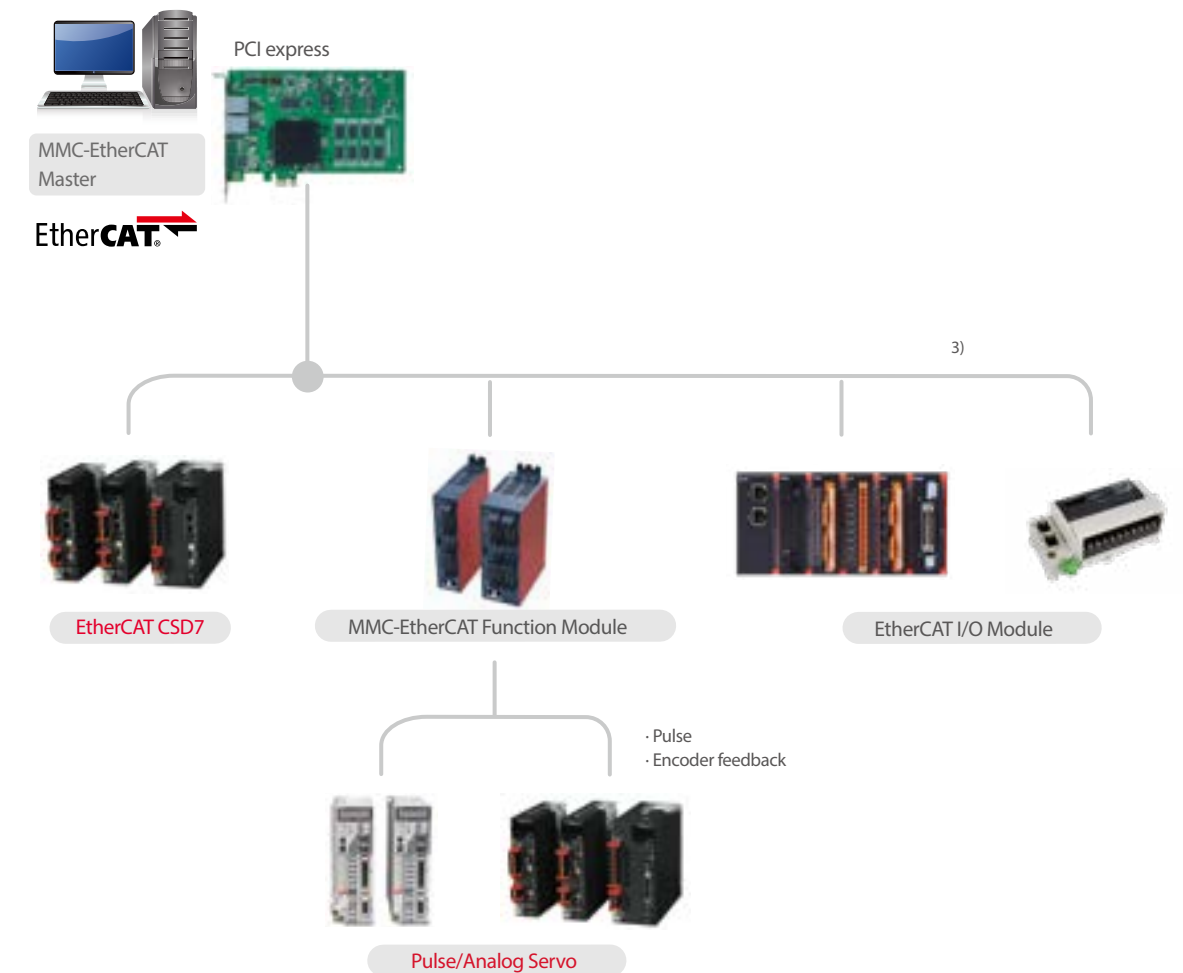

3) Max distance between nodes is 100m.



Drive and Motor Selection

■ Servo Drive Model Designations

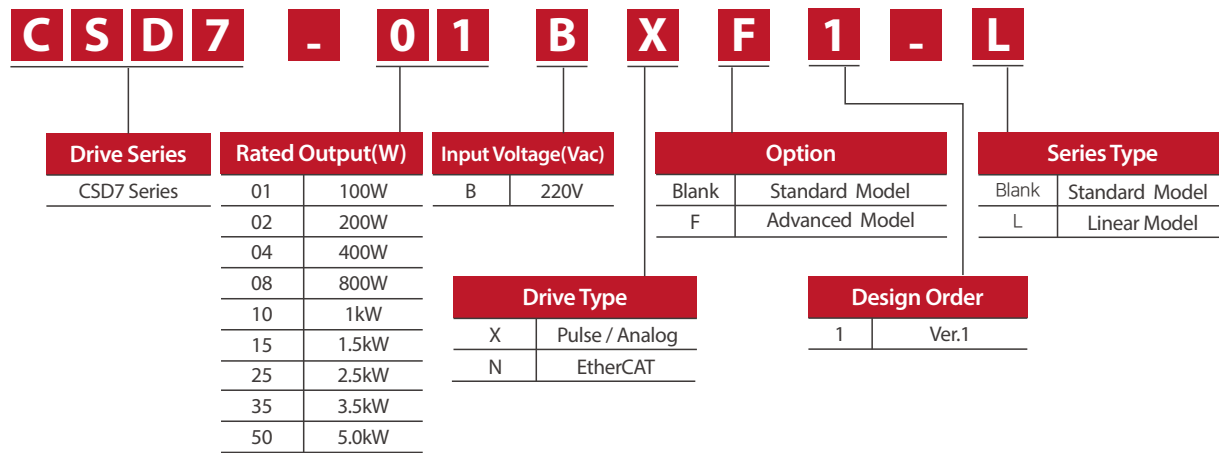

■ Servo Motor Model Designations

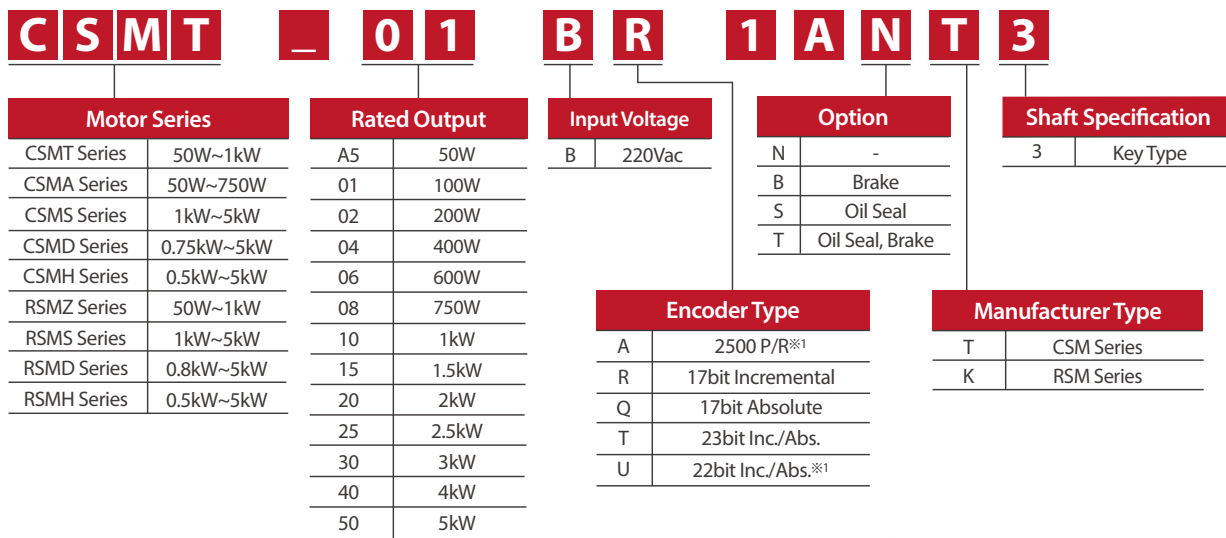

※1 Contact RSA for the corresponding model.

■ Available motor Series

Motor Series	Item	Rated Output	Rated/Max. speed (rpm)	Motor Type	Encoder	Protection Degree	Inertia
CSMA		50W~100W	3000/6000	Cylinder	23bit serial Abs/Inc	IP 67 ^{※2}	Ultra Low Inertia
		200W~750W	3000/5000				
CSMT		50W~950W	3000/5000		17bit serial Abs/Inc	IP 65 ^{※2}	Low Inertia
CSMS		1kW~5kW	2000/3000		23bit serial Abs/Inc		
CSMD		750W~5kW	2000/3000		2500 P/R	17/22bit serial Abs/Inc	High Inertia
CSMH		500W~5kW	3000/5000				
RSMZ		50W~600W ^{※1}	3000/5000		2500 P/R	17/22bit serial Abs/Inc	Ultra Low Inertia
		800W	3000/4500				
		950W	3000/3500				
RSMS		1kW~3.5kW	3000/5000		17bit serial Abs/Inc	IP 65 ^{※2}	Low Inertia
		4kW~5kW	3000/4500				
RSDM		750W~5kW	2000/3000	17bit serial Abs/Inc	Medium Inertia	High Inertia	
RSMH		500W~5kW	2000/3000	2500 P/R	17bit serial Abs/Inc		

※1 600W motor does not support 22-bit resolution encoder.

※2 Except rotating part of ourput shaft, connecting pin of motor connector and encoder connector.

Motor Line-up

The CSM, RSM motor series is composed of a wide range of power ratings, so it is available to select the optimal product according to the purpose of use.

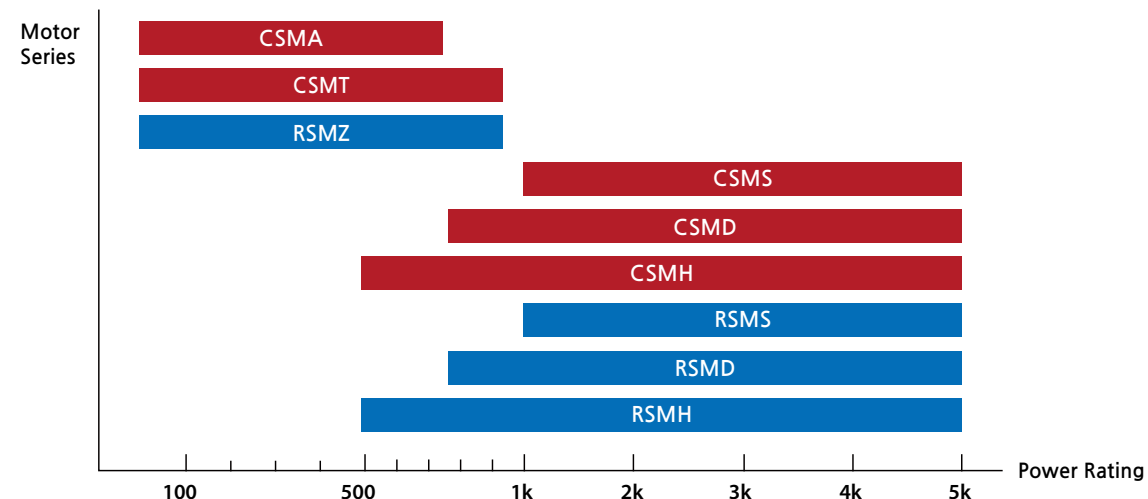

Motor - Drive Matching Table * X : No motor available for the capacity.

Capacity	Motor	CSMA (Ultra Low Inertia)	CSMT (Ultra Low Inertia)	CSMS (Low Inertia)	CSMD (Medium Inertia)	CSMH (High Inertia)	RSMZ (Ultra Low Inertia)	RSMS (Low Inertia)	RSMD (Medium Inertia)	RSMH (High Inertia)
50W	CSD7_01B**1	X	X	X	X	X	X	X	X	X
100W	CSD7_01B**1	X	X	X	X	X	X	X	X	X
200W	CSD7_02B**1	X	X	X	X	X	X	X	X	X
400W	CSD7_04B**1	X	X	X	X	X	X	X	X	X
500W	X	X	X	X	X	CSD7_04B**1 or CSD7_08B**1	X	X	X	CSD7_08B**1
600W	CSD7_08B**1	X	X	X	X	X	X	X	X	X
750W	CSD7_08B**1	X	X	X	X	X	X	X	X	X
1kW	X	CSD7_10B**1	CSD7_10B**1	CSD7_10B**1	CSD7_08B**1 or CSD7_10B**1	CSD7_08B**1 or CSD7_10B**1	CSD7_10B**1	CSD7_10B**1	CSD7_10B**1	CSD7_10B**1
1.5kW	X	X	X	CSD7_15B**1	CSD7_15B**1	CSD7_15B**1	X	CSD7_15B**1	CSD7_15B**1	CSD7_15B**1
2kW	X	X	X	CSD7_15B**1 or CSD7_25B**1	CSD7_25B**1	CSD7_25B**1	X	CSD7_25B**1	CSD7_25B**1	CSD7_25B**1
2.5kW	X	X	X	CSD7_25B**1	CSD7_25B**1	X	X	CSD7_25B**1	CSD7_25B**1	X
3kW	X	X	X	CSD7_35B**1	CSD7_35B**1	CSD7_35B**1	X	CSD7_35B**1	CSD7_35B**1	CSD7_35B**1
3.5kW	X	X	X	X	X	X	X	CSD7_35B**1	CSD7_35B**1	X
4kW	X	X	X	CSD7_35B**1 or CSD7_50B**1	CSD7_35B**1 or CSD7_50B**1	CSD7_50B**1	X	CSD7_50B**1	CSD7_50B**1	CSD7_50B**1
4.5kW	X	X	X	X	X	X	X	CSD7_50B**1	CSD7_50B**1	X
5kW	X	X	X	CSD7_50B**1	CSD7_50B**1	CSD7_50B**1	X	CSD7_50B**1	CSD7_50B**1	CSD7_50B**1

CSD7 Series Specifications

Common Specifications

Item	Catalog No.	01B**1(L)	02B**1(L)	04B**1(L)	08B**1(L)	10B**1(L)	15B**1(L)	25B**1	35B**1	50B**1	
Output	Rated Current [Arms]	1.1	1.8	3.3	6.2	8.0	11.0	16.0	22.0	32.1	
	Maximum Current [Arms]	3.3	5.4	9.9	18.6	24.0	33.0	48.0	66.0	96.3	
Main Power Supply	Voltage Range	Single-phase AC 200 ~ 230Vrms, +10%, -15%, 50/60Hz				3-phase AC 200 ~ 230 Vrms, +10%, -15%, 50/60Hz For 800w, single-phase can be used by changing parameter					
	Input Current [Arms]	1.1	2.1	4.0	5.5/7.8	7.7	11.1	17.1	23.9	33.8	
Control Power Supply		Single-phase AC 200 ~ 230 Vrms, +10%, -15%, 50/60Hz									
Encoder, Auxiliary Encoder		17 & 23 Bit Serial Absolute/Incremental, 21 Bit BiSS, AqB Incremental									
Internal Shunt Resistor		-	-	50Ω/30W	30Ω/100W			12Ω/150W	8Ω/250W		
Dynamic Brake		Provide built-in circuit that shorts two phase(U,V) of motor						Support built-in circuit, 3-phase(U,V,W) the short-circuited via a resistor of 0.5Ω/100W			
Communication		USB Connect to PC to use serial communication. RSWare should be used through this port.									
Environment	Operating Temperature/ Humidity	0°C ~ 50°C/90% RH or below (Non-condensing)									
	Storage Temperature/ Humidity	-20°C ~ 85°C/90% RH or below (Non-condensing)									
	Vibration/Shock	Vibration : 2G or below, Shock : 15G or below (1G = Gravity Acceleration, 9.8m/s ²)									
	IP Rating/Pollution Degree	IP20 / Pollution Degree 2									
Allowed Altitude		Max. 1000m above sea level									
Protective Function		Over Current, Motor Overload, Drive Overload, Regeneration Overload, Over Voltage, Low Voltage, Over Speed, Over Heat, CPU Fault, Encoder Fault, Communication Fault, IPM Fault, Abnormal Motor Speed Setting, Excessive Position Error, AC Line Phase Loss, Motor Cable Open, etc.									
Auxiliary encoder		17 & 23 Bit Serial , 21 Bit BiSS format support / Hall signal support (Linear Servo)									
Functional Safety*	Functions	STO(Safe Torque Off, IEC/EN 61800-5-2), MTTFd:3,830Years, DC.Low, 69.4%, PFH:6.3257x10e-8(1/h)									
	Standards	IEC/EN 61508 SIL2, EN ISO 13849-1 PL d, Certified by TUV SUD									
Certification	CE Standard	LVD:EN61800-5-1:2007, EMC:EN61800-3:2004+A1:2012, Certified by TUV SUD									
	NRTL/C standard	UL508C:2013, CSA C22.2 No.14:2013, Certified by TUV SUD									
KC		KN 61800-3:2014									
Cooling method		Fan Cooling				Fan Cooling					
Installation	Mounting Method	Base Mounted (Standard), Rack Mounted(Need Optional Mechanical Parts)					Base Mounted				
	Zero Stacking	It can be mounted without space between products.									

Pulse/Analog Model

Item	Catalog No.	01BX(F)1(L)	02BX(F)1(L)	04BX(F)1(L)	08BX(F)1(L)	10BX(F)1(L)	15BX(F)1(L)	25BXF1	35BXF1	50BXF1
Communication		RS-485 Support 1: N Multi-Drop function and 32-axis operation, set the axis number by a parameter								
I/O Spec.	Encoder Output	A, B and Z pulse output, Line Driver output, Division ratio: N/M (N,M≤32768), Absolute position can be sent by serial data.								
	Digital Input	Function allocable 8 points; fixed 1 point (emergency stop); input response time: 6ms to 8ms								
	Output	High speed allocable 2 points: general function allocation allowed, position registration, input response time: 5us or under								
Position Control	Command Input Circuit	Function allocable 6 points, Fixed 2 points(Encoder Z-pulse, Servo fault indicator)								
	Position Command Type	CCW+CW pulse train, Sign+Pulse train, A+B pulse train (90°phase difference between A and B)								
	Maximum Input Frequency	Line Driver(SV), Open Collector (5V-external resistor required, 24V-need not external resistor)								
	Electronic Gear Ratio	4Mpps (Line Driver), 250Kpps (Open Collector)								
Velocity control	Feedforward Compensation	3 sets of electronic gears provided								
	Command Type	0 - 100% (Setting Unit : 1%)								
	Range of Control	Analog Velocity Command, Preset Velocity Command								
	Velocity Variation	Analog Velocity Command (1 : 2000), Preset Velocity Command (1 : 5000)								
	Acceleration/Deceleration Setting Range	Input voltage variation (AC 170 ~ 253 Vrms AC): 0%, Load variation (0-100%): ±0.01% Max, Temperature variation (25°C±25°C):±0.1%								
Torque Control	Analog Velocity Command*	0 - 60 sec								
	Command Type	DC 0V - ± 10V (For default value, 6V is set as a rated speed.)								
	Analog Torque Command*	DC 0V - ±10V (For default value, 3V is set as a rated torque.)								
Control Accuracy (Repeatability)		± 1%								
Built-in Operator		1. Six 7-segment LED; 2. Four buttons for Parameter setting								
Analog Monitor Function*		2 Points, DC ± 10V, max current : ± 10mA, 12Bit resolution								

Network Model

Item	Catalog No.	01BN(F)1(L)	02BN(F)1(L)	04BN(F)1(L)	08BN(F)1(L)	10BN(F)1(L)	15BN(F)1(L)	25BNF1	35BNF1	50BNF1
Communication		EtherCAT IEC 61800-7 CIA 402 Drive Profile, CoE, 100BASE-TX(IEEE802.3) EtherCAT CoE, Max. 100m distance between nodes.								
I/O Spec.	Encoder Output	A,B Pulse Output, Line Driver Output, Division Ratio : N/M(N,M≤32768)								
	Digital Input	Function allocable 4 points, Fixed 1 point(Emergency Stop), Response Time : 6ms ~ 8ms								
	Digital Output	High Speed Input 2 points, Position Registration (Touch Probe), Response Time : 5us or under								
Built-in Operator		Function allocable 3 points								
Built-in Operator		1. Six 7-segment LED for display, 2. Four buttons for parameter editing, 3. Two LED for Indicating EtherCAT communication status								

* This function is applied only on CSD7 Advanced models.

Dimensions

■ 100W - 200W

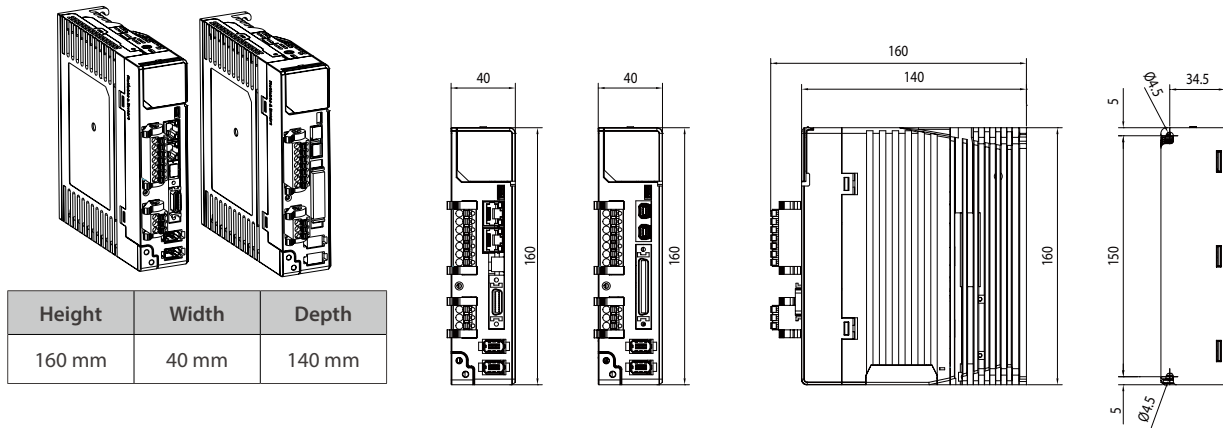

Height	Width	Depth
160 mm	40 mm	140 mm

■ 400W

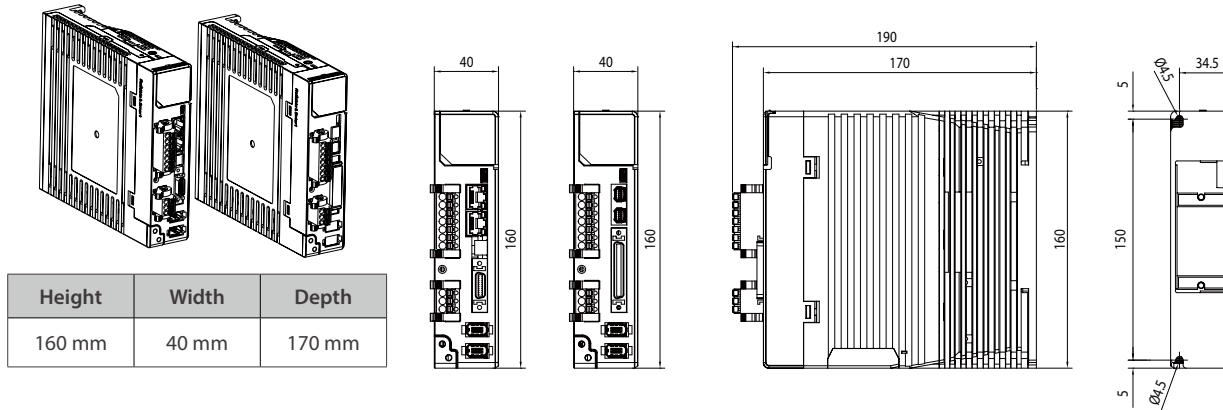

Height	Width	Depth
160 mm	40 mm	170 mm

■ 800W - 1.5KW

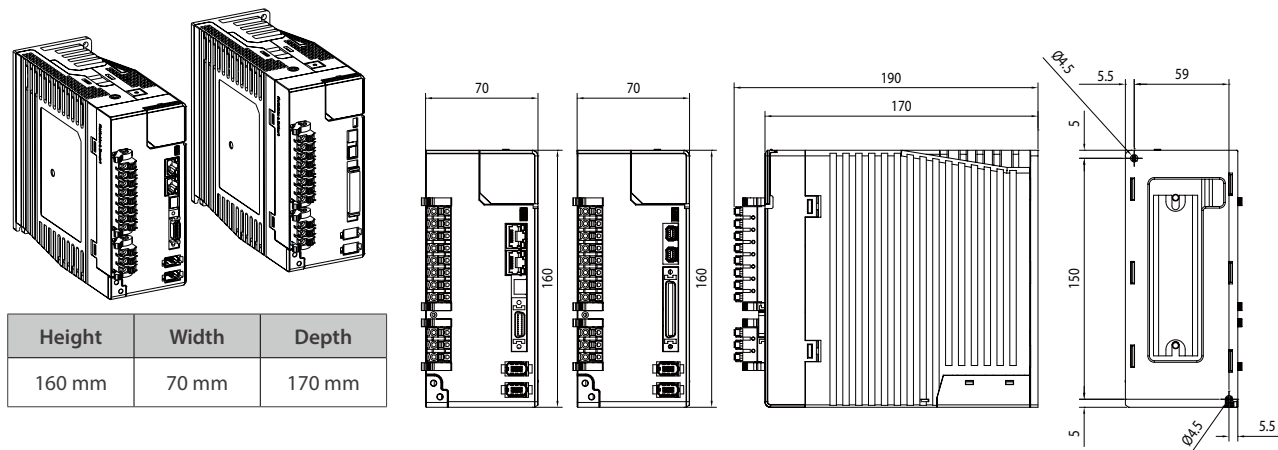

Height	Width	Depth
160 mm	70 mm	170 mm

[Notice]

• The CAD data of the above dimensions are available to download from our company website. (<http://www.rsautomation.co.kr> or <http://www.rsautomation.biz>)

■ 2.5kW ~ 3.5kW

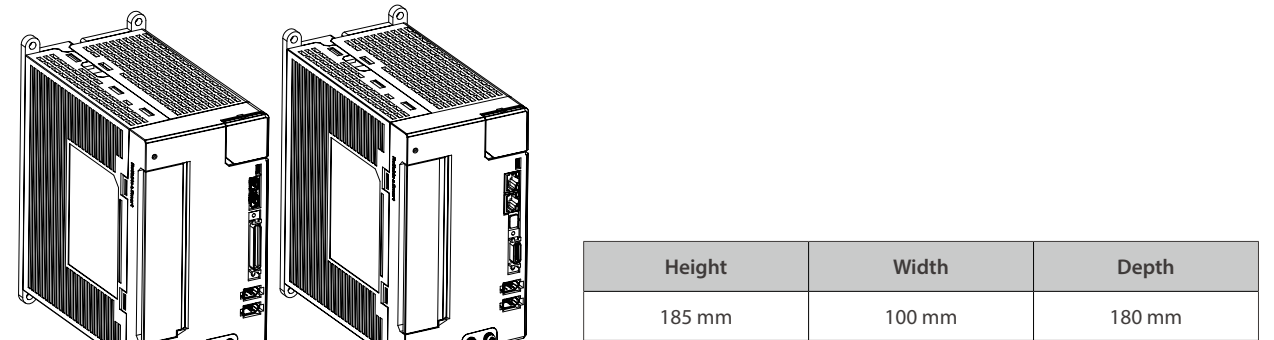

Height	Width	Depth
185 mm	100 mm	180 mm

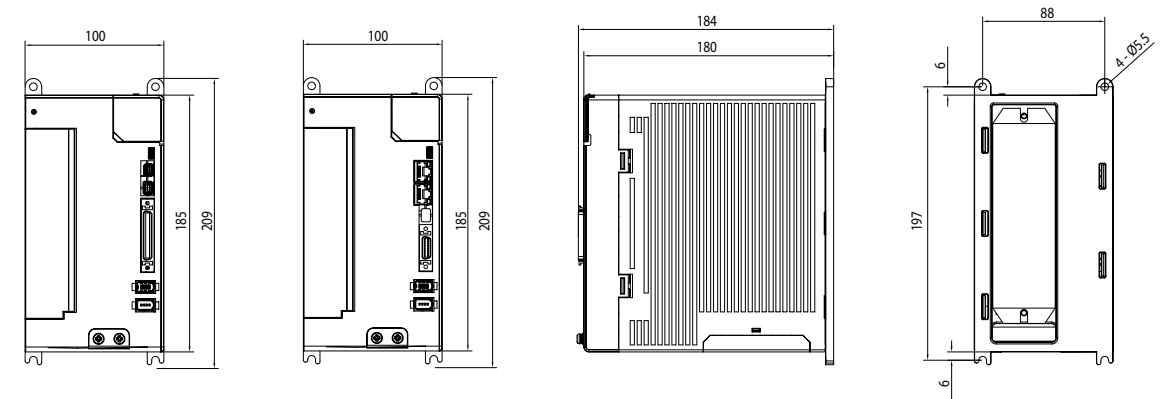

■ 5kW

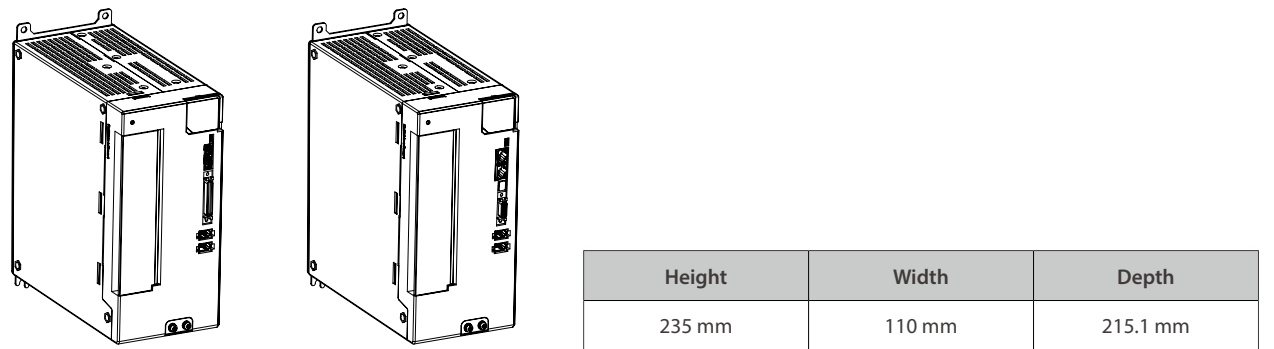

Height	Width	Depth
235 mm	110 mm	215.1 mm

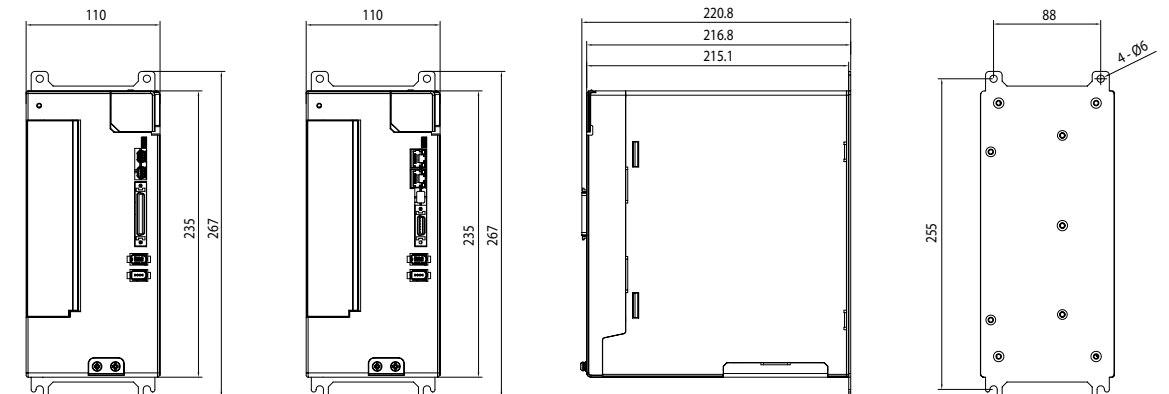

Product Interface

■ Pulse / Analog Model

- **Rated Output (Small-Capacity)**
 - 100W ~ 200W
 - 400W
 - 800W ~ 1.5kW

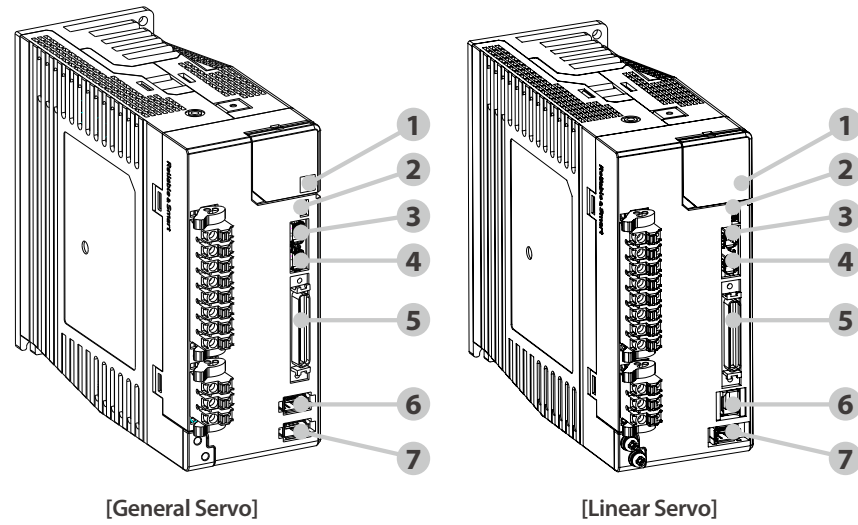

- **Rated Output (Medium-Capacity)**
 - 2.5kW ~ 3.5kW
 - 5kW

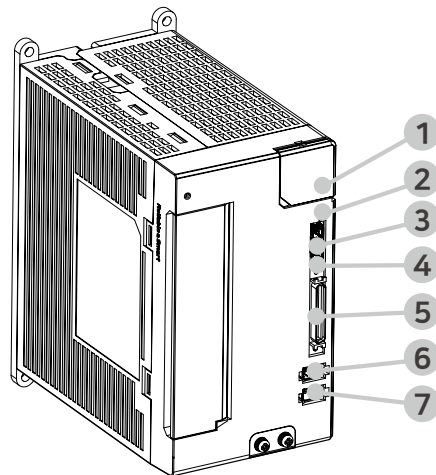

NO.	Item	Function
1	Built-in Operator	It consist of six 7-segments and four push buttons. It provide some functions such as parameter editing, status display, monitoring, Run functions.
2	USB	Connect to the PC Software, RSWare
3	COMM	Connect to the Modbus-RTU(RS-485) communication
4	Safety	Safety function (STO)
5	I/O	This 50 pin connector is for interface with external device. The functions are command input, System Input/Output, User Input/Output, fault output, Encoder output. For more detail, refer to the wiring diagram.
6	ENC	Encoder signal is fed into this connector. : 17bit serial encoder, 23bit serial encoder, 21bit BiSS / AqB (Linear)
7	ENC ^{AUX}	This is for full closed control which is aimed at adjusting mechanical position error. Linear scale signal is fed into this connector (General Servo) / Hall signal input (Linear Servo)

■ EtherCAT Model

- **Rated Output (Small-Capacity)**
 - 100W ~ 200W
 - 400W
 - 800W ~ 1.5kW

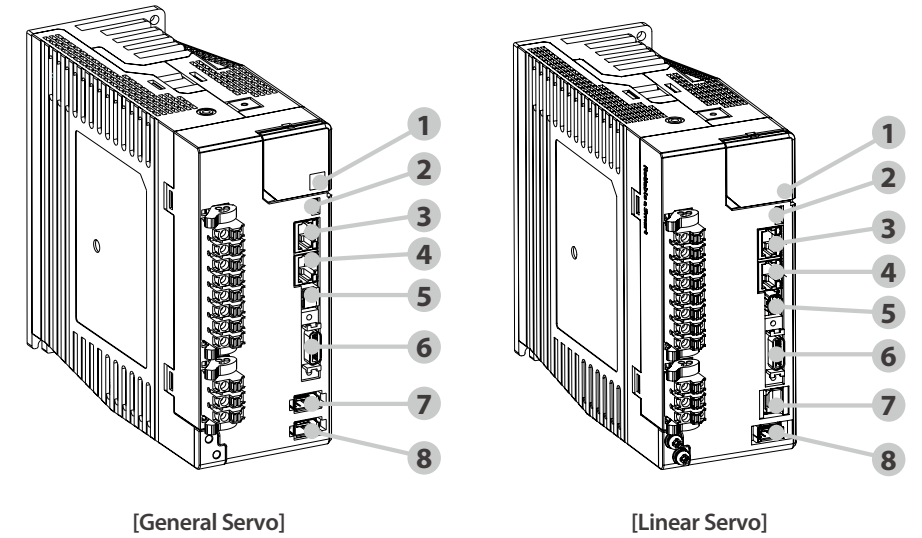

- **Rated Output (Medium-Capacity)**
 - 2.5kW ~ 3.5kW
 - 5kW

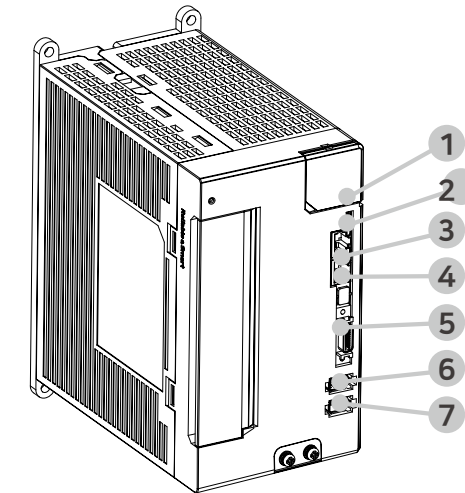

NO.	Item	Function
1	Built-in Operator	It consist of six 7-segments, four push buttons and two LEDs. It provide some functions such as parameter editing, status display, monitoring, Run functions, EtherCAT communication status.
2	USB	Connect to the PC Software, RSWare
3	ECAT IN	EtherCAT communication signal Input
4	ECAT OUT	EtherCAT communication signal Output
5	Safety	Safety function (STO)
6	I/O	This 20 pin connector is for interface with external device. The functions are System Input/Output, User Input/Output, fault output, Encoder output. For more detail, refer to the wiring diagram.
7	ENC	Encoder signal is fed into this connector. : 17bit serial encoder, 23bit serial encoder, 21bit BiSS / AqB (Linear)
8	ENC ^{AUX}	This is for full closed control which is aimed at adjusting mechanical position error. Linear scale signal is fed into this connector (General Servo) / Hall signal input (Linear Servo)

Wiring Diagram (1)

Pulse / Analog Model

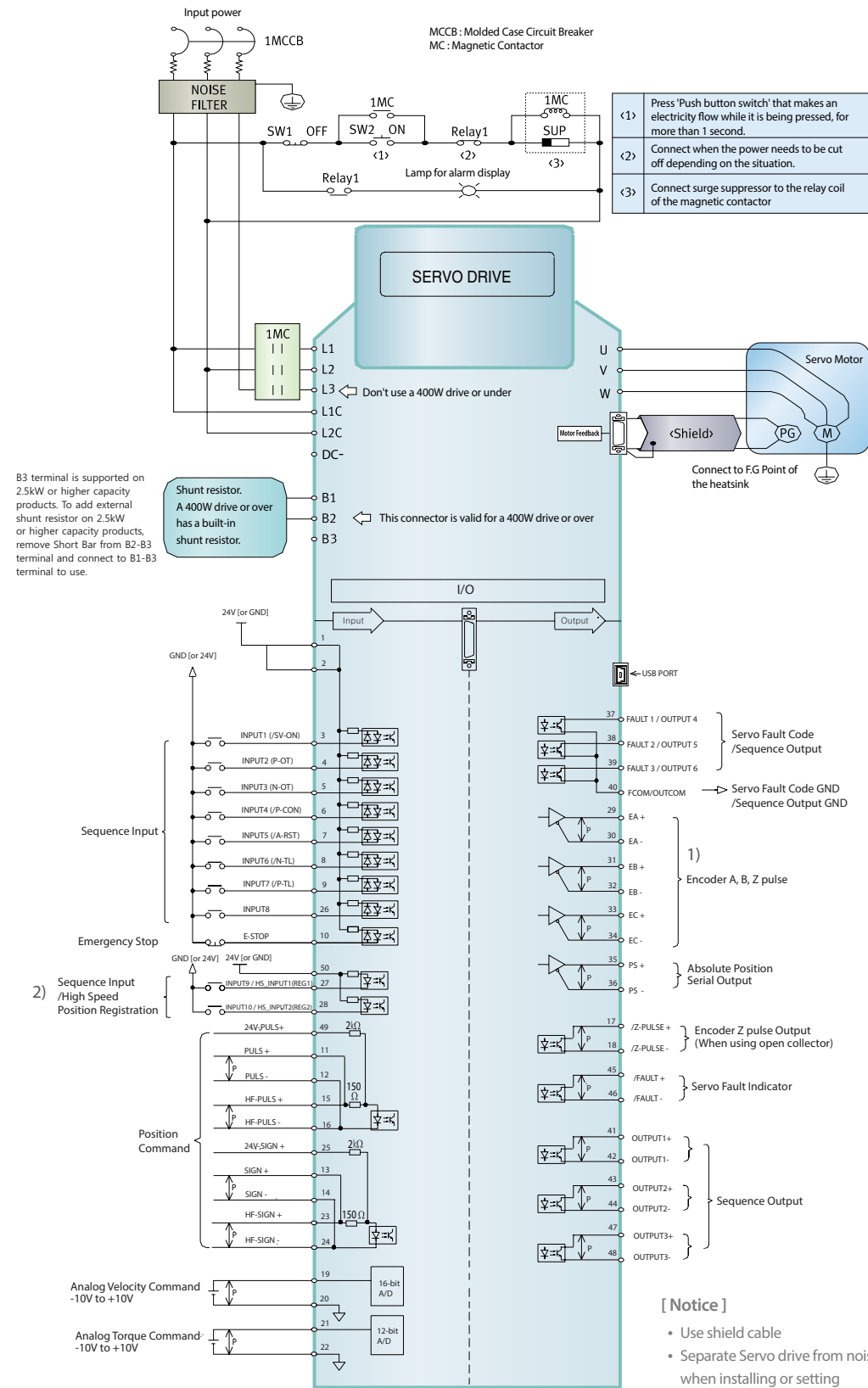

- 1) Every ↑ P represents a twisted pair of the wire.
- 2) HS_INPUT1 and HS_INPUT2 are for high speed input that can read position data less than 3us after signal input.

Wiring Diagram (2)

EtherCAT Model

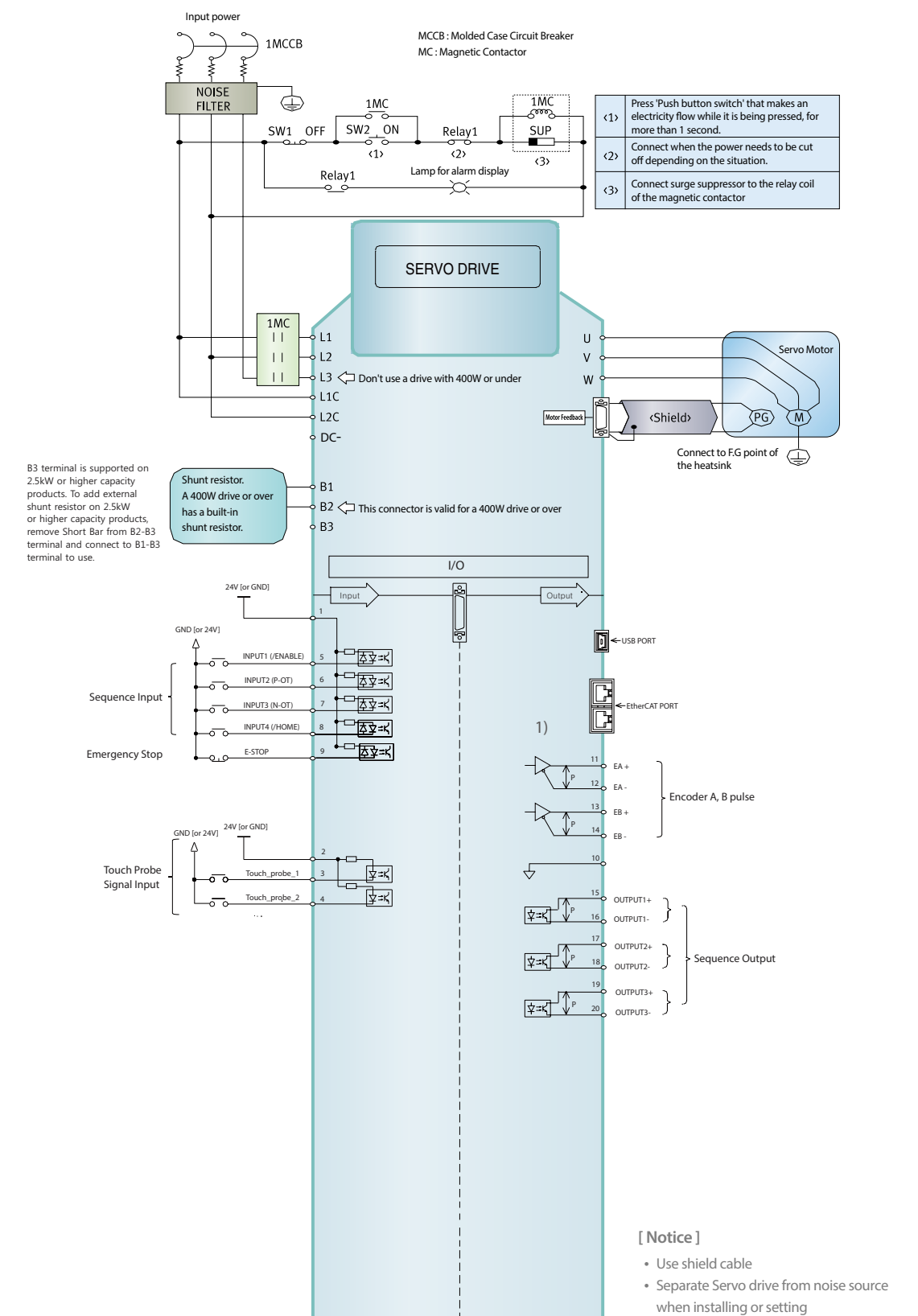

- 1) Every ↑ P represents a twisted pair of the wire.

CSMA Motor

Basic Specifications

Item	Category	Unit	CSMA_					
			A5B	01B	02B	04B	06B	08B
Flange Size		mm	40	40	60	60	80	80
Rated Output		W	50	100	200	400	600	750
Rated Speed		r/min	3,000	3,000	3,000	3,000	3,000	3,000
Max. Speed		r/min	6,000	6,000	5,000	5,000	5,000	5,000
Rated Torque		N·m	0.159	0.318	0.64	1.27	1.91	2.39
		kgf·cm	1.62	3.25	6.5	13.0	19.5	24.4
Max. Instantaneous Torque		N·m	0.56	1.11	2.24	4.46	6.69	8.36
		kgf·cm	5.7	11.4	22.9	45.5	68.2	85.3
Rated Current		A(rms)	0.7	0.9	1.7	2.8	4.4	4.9
Max. Instantaneous Current		A(rms)	2.4	3.0	5.9	9.5	15.1	16.6
Rotor Moment of Inertia		X10 ⁻⁴ kg·m ²	0.019	0.035	0.15	0.27	0.71	0.86
		gf·cm·sec ²	0.020	0.036	0.15	0.28	0.73	0.88
Rotor Moment of Inertia (Brake)		X10 ⁻⁴ kg·m ²	0.024	0.039	0.20	0.35	0.88	1.04
		gf·cm·sec ²	0.024	0.040	0.20	0.36	0.90	1.06
Electrical Time Constant		ms	0.8	0.9	2.8	3.2	4.3	4.7
Mechanical Time Constant (Non Brake)		ms	0.6	0.5	0.4	0.4	0.4	0.4
Mechanical Time Constant (Brake)		ms	0.8	0.6	0.6	0.5	0.5	0.4
Power Rate (Non Brake)		kW/s	12.9	28.7	27.4	59.2	51.2	65.9
Power Rate (Brake)		kW/s	10.8	25.8	20.7	46.2	41.4	55.0
Dielectric Withstand Voltage		-	AC1500V, 60s					
Input Voltage		VAC	AC 200					
Insulation Class		-	Class F					
Insulation Resistance		MΩ MIN	100 (at DC 500V)					
Shaft Friction Torque		N·m Max	0.02	0.04	0.04	0.08	0.08	0.08
		kgf·cm Max	0.2	0.4	0.4	0.8	0.8	0.8
Allowable Thrust Shaft Load		N	39.2	68.6	68.6	98	98	98
		kgf	4	7	7	10	10	10
Allowable Radial Shaft Load		N	78.4	196	196	343	343	343
		kgf	8	20	20	35	35	35
Shaft End Play		mm Max	0.2					
Color		-	Black					
Weight (Non Brake)		kg	0.4	0.5	0.9	1.3	2.2	2.5
Weight (Brake)		kg	0.6	0.7	1.4	1.8	3.1	3.4

[Caution]

1. Suppose to attach Aluminum Heat Sink(305x305xT12mm) on Motor when using the rated torque. Ambient temperature should be below 40°C.
2. All values were measured between 20~30°C.
3. Each value is derived when the motor is used with matched drive.
4. Inertia, Rated Current, Instantaneous Maximum Current, Electrical Time Constant, Mechanical Time Constant, Power Rate, Shaft Friction Torque and Product weight might change by using Brake, Oil Seal Type.
5. Keep the temperature of motor's surface below 85°C.

CSMA Motor - Torque Speed Curves

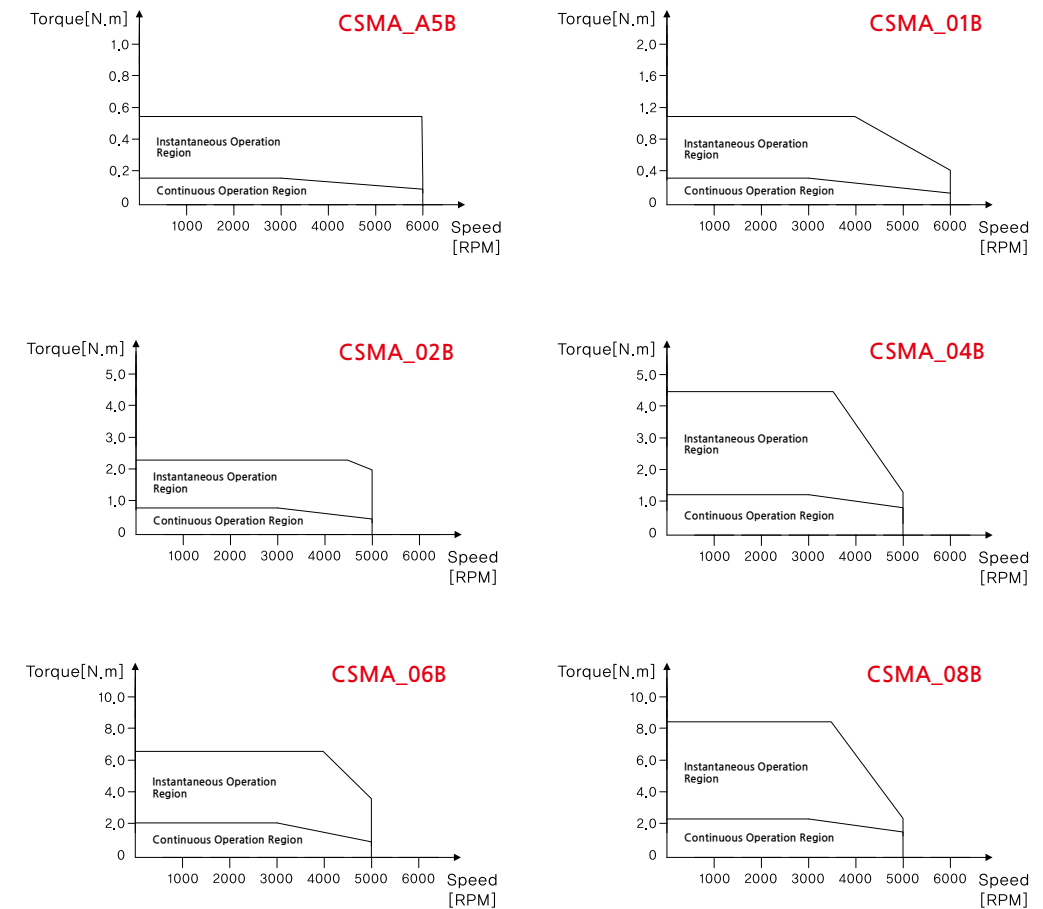

CSMA Motor - Holding Brake Specification

Item	Category	Unit	CSMA_					
			A5B	01B	02B	04B	06B	08B
Rated Voltage		VDC	DC 24V ±10%					
Static Friction Torque		N·m MIN (kgf·cm MIN)	0.318 (3.24)	0.318 (3.24)	1.27 (13)	1.27 (13)	2.39 (24.4)	2.39 (24.4)
Power Consumption (20 °C)		W	4	4	8	8	8	8
Brake Absorbing Time		ms MAX	40	40	50	50	60	60
Brake Releasing Time		ms MAX	20	20	20	20	30	30

■ CSMA Motor -External Dimension outline

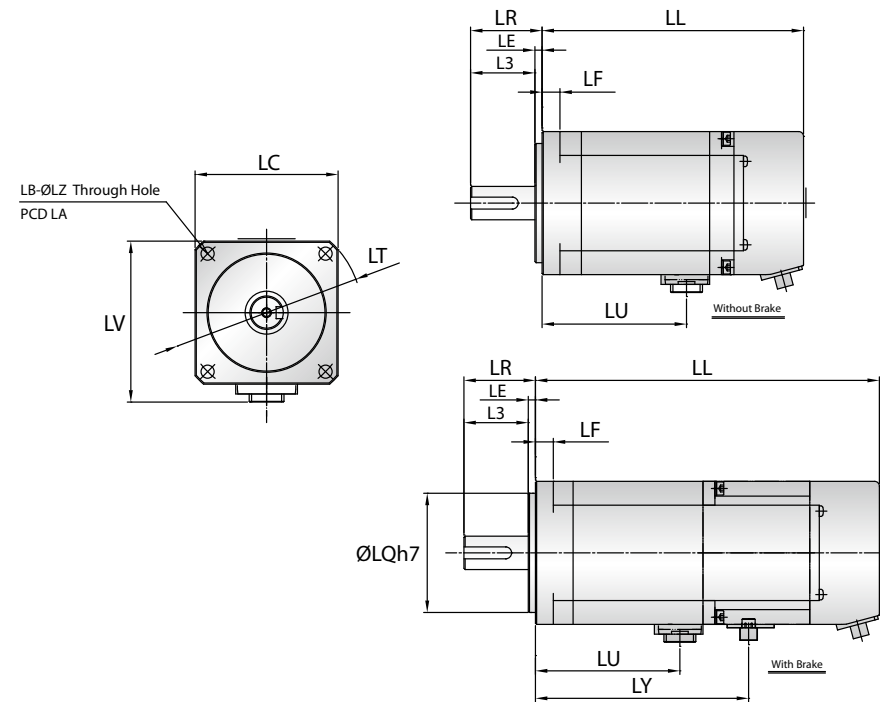

■ CSMA Motor - External Dimension

Item	Motor	Unit	CSMA_					
			A5B	01B	02B	04B	06B	08B
LL	Non Brake		76.5	90.5	87.7	109.7	109.8	116.8
	Brake		112	126	122.3	144.3	147.9	154.9
LU	Non Brake		30.15	44.15	38.1	60.1	59.55	66.55
	Brake		30.15	44.15	38.1	60.1	58.15	65.15
LY	Brake Only		-	-	-	-	-	-
	LR		25	25	30	30	35	35
	L3		22.5	22.5	27	27	32	32
	LE		2.5	2.5	3	3	3	3
	LF		6.5	6.5	7.5	7.5	12	12
	LQ		30	30	50	50	70	70
	LC		40	40	60	60	80	80
	LV		48.3	48.3	67.5	67.5	87.4	87.4
	LT		-	-	80	80	105	105
	LB		2	2	4	4	4	4
	LZ		4.5	4.5	5.5	5.5	6.6	6.6
	LA		46	46	70	70	90	90

■ CSMA Motor - Shaft Dimension

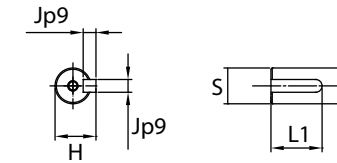

Item	Motor	CSMA_					
		A5B	01B	02B	04B	06B	08B
S		8	8	14	14	19	19
L1		16	16	20	20	25	25
Jp9		3	3	5	5	6	6
H		9.2	9.2	16	16	21.5	21.5

■ CSMA Motor - Connector Specifications

Item	Category	Motor		Brake		Encoder	
		Pin no.	Function	Pin no.	Function	Pin no.	Function
Pin spec.		1	F.G	1	Brake	1	BAT+
		2	U	2	Brake	2	BAT-
		3	V	-		3	SD
		4	W		4	/SD	
					5	Vcc (+5V)	
						6	GND (0V)
						7	-
Outline							
		JN6A504NJ1 (JAE)	JN6CR02PM1 (JAE)	JN6CR07PM1 (JAE)			
Mating plug							
		JN6FS04SJ2 (JAE)	JN6FR02SM1 (JAE)	JN6FR07SM1 (JAE)			
		ST-JN5-S-C1B-2500	LY10-C2-A1-10000	LY10-C2-A1-10000			

CSMT Motor

Basic Specifications

Item	Category	Unit	CSMT_						
			A5B	01B	02B	04B	06B	08B	10B
Flange Size	mm		40	40	60	60	80	80	86
Rated Output	W		50	100	200	400	600	800	1000
Rated Speed	r/min		3000						
Max. Speed	r/min		5000						
Rated Torque	N·m		0.16	0.32	0.64	1.27	1.91	2.39	3.0
	kgf·cm		1.62	3.25	6.5	13	19.5	24.4	30.9
Max. Instantaneous Torque	N·m		0.48	0.95	1.91	3.82	5.73	7.16	9.1
	kgf·cm		4.9	9.7	19.5	39	58.5	73	92.6
Rated Current	A(rms)		0.6	1.1	1.7	3.3	4.4	5	7
Max. Instantaneous Current	A(rms)		1.6	3	5.0	9.7	12.9	14.5	20.4
Rotor Moment of Inertia (Non Brake)	gf·cm·sec ²		0.02	0.03	0.18	0.34	1	1.1	1.56
	x10 ⁻⁴ kg·m ²		0.02	0.03	0.18	0.34	0.98	1.08	1.53
Rotor Moment of Inertia (Brake)	gf·cm·sec ²		0.05	0.06	0.28	0.44	1.24	1.34	1.66
	x10 ⁻⁴ kg·m ²		0.05	0.06	0.28	0.44	1.22	1.32	1.63
Electrical Time Constant	ms		0.9	0.6	0.9	0.6	0.6		
Mechanical Time Constant	ms		1.1	1.6	3.2	3.8	6	4.8	5.7
Power Rate	kW/s		12.9	34.5	23	48.7	37.3	51.3	56.4
Shaft Friction Torque	kgf·cm MAX		0.2		0.4		0.8		1.5
Shaft Friction Torque	mm MAX		0.2						
Allowable Thrust Shaft Load	kgf MAX		4	4	7	7	10		
Allowable Radial Shaft Load	kgf MAX		8		20		35		
Color	-		Black						
Weight	Kg		0.4	0.5	0.9	1.3	2.2	2.5	3.7
Input Voltage	VAC		220						

[Caution]

1. Suppose to attach Aluminum Heat Sink(305x305xT12mm) on Motor when using the rated torque. Ambient temperature should be below 40°C.
2. All values were measured between 20~30°C.
3. Each value is derived when the motor is used with matched drive.
4. Inertia, Rated Current, Instantaneous Maximum Current, Electrical Time Constant, Mechanical Time Constant, Power Rate, Shaft Friction Torque and Product weight might change by using Brake, Oil Seal Type.
5. Keep the temperature of motor's surface below 85°C.

CSMT Motor - Torque Speed Curves

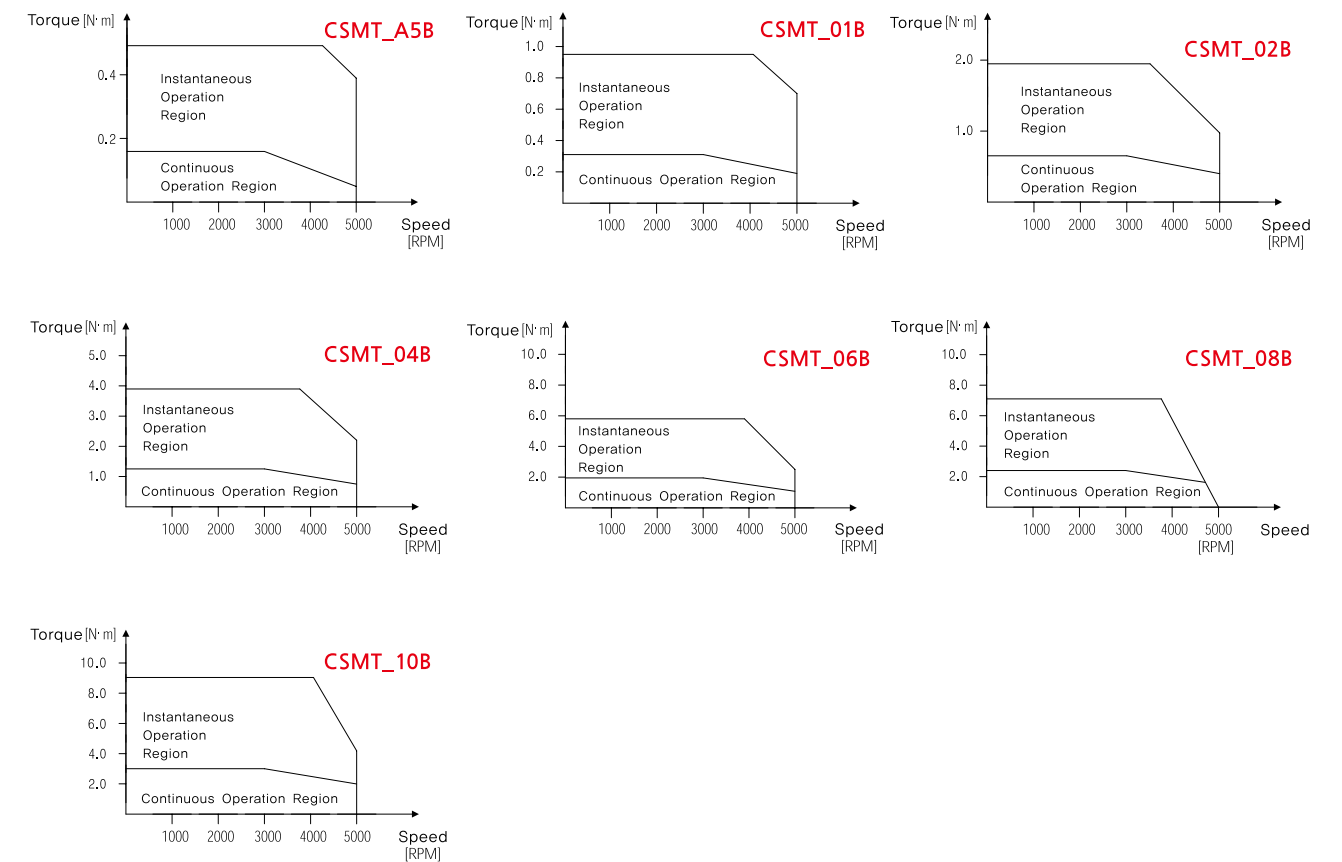

CSMT Motor - Holding Brake Specification

Item	Category	Unit	CSMT_					
			A5B	01B	02B	04B	06B	08B
Rated Voltage	VDC		DC 24V ±10%					
Static Friction Torque	N·m MIN (kgf·cm MIN)		0.32 (3.25)		1.27 (13)		2.39 (24.4)	
Power Consumption (20 °C)	W		4		8		8	
Brake Absorbing Time	ms MAX		40		50		60	
Brake Releasing Time	ms MAX		20				30	

■ CSMT Motor - External Dimension outline

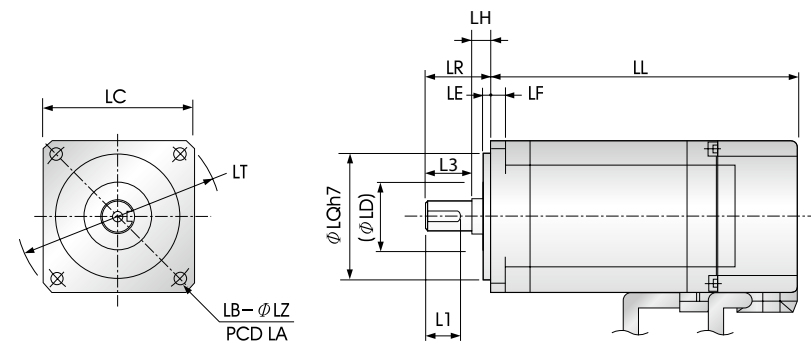

■ CSMT Motor - External Dimension

Item	Motor	Unit	CSMT_						
			A5B	01B	02B	04B	06B	08B	10B
LL	Non Brake		59.5	109.1	110.7	132.7	136.3	145.3	144.2
	Brake		95.1	73.5	76.1	98.1	99.7	108.7	167.2
	LR		25	25	30	30	35	35	35
	LE		2.5	2.5	3	3	3	3	3
	LF		5	5	6	6	8	8	8
	LH		4.5	4.5	7	7	7	7	7
	LQ		30	30	50	50	70	70	80
	LD		20	20	27	27	34	34	34
	L1		17	17	18	18	23	23	23
	L3		20	20	22	22	27	27	27
	LC		40	40	60	60	80	80	86
	LT		55	55	80	80	105	105	112
	LB		2	2	4	4	4	4	4
	LZ		4.5	4.5	5.5	5.5	6.6	6.6	6.6
	LA		46	46	70	70	90	90	100

■ CSMT Motor - Shaft Dimension

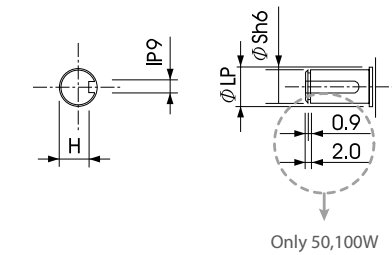

Item	Motor	CSMT_					
		A5B	01B	02B	04B	06B	08B
	LP	8.9		14		19.8	
	Sh6	8		12		16	
	H	6.2		9.5		13	
	Ip9	3		4		5	

■ CSMT Motor - Connector Specification

Item	Category	Motor	Brake	Encoder		
Part no.		172167-1(AMP) 170360-1 170364-1	172165-1(AMP) 170359-1 170363-1	172169-1(AMP) 770835-1		
Pin spec.	Pin no.	Function	Pin no.	Function	Pin no.	Function
	1	U	1	BR	1	BAT+
	2	V	2	BR	2	BAT-
	3	W			3	shield
	4	FG			4	SD+
					5	SD-
					6	-
			7	E5[V]		
			8	E0[V]		
		9	-			
Outline						

CSMS Motor

Basic Specifications

Item	Category	Unit	CSMS_						
			10B	15B	20B	25B	30B	40B	50B
Flange Size		mm	100	100	100	100	130	130	130
Rated Output		kW	1	1.5	2	2.5	3	4	5
Rated Speed		r/min	3,000	3,000	3,000	3,000	3,000	3,000	3,000
Max. Speed		r/min	5,000	5,000	5,000	5,000	5,000	5,000	5,000
Rated Torque		N·m	3.2	4.8	6.4	7.9	9.6	12.7	15.9
		kgf·cm	32.7	48.7	65.3	80.6	97.4	129.6	162.2
Max. Instantaneous Torque		N·m	9.6	14.3	19.2	23.7	28.5	37.9	47.6
		kgf·cm	98	145.9	195.9	241.8	290.8	386.7	485.7
Rated Current		A(rms)	6.8	9.3	11.6	15.7	18.5	22.9	27.8
Max. Instantaneous Current		A(rms)	20.5	28.7	33.1	45	53.7	65.9	81.2
Rotor Moment of Inertia		X10 ⁻⁴ kg·m ²	1.99	2.85	3.7	4.57	7.71	12.63	12.63
		gf·cm·sec ²	2.03	2.91	3.78	4.66	7.87	12.89	12.89
Rotor Moment of Inertia (Brake)		X10 ⁻⁴ kg·m ²	2.34	3.17	4.02	4.88	8.59	13.52	13.52
		gf·cm·sec ²	2.36	3.23	4.11	4.98	8.77	13.8	13.8
Electrical Time Constant		ms	5.6	6.1	6.1	6.4	7.7	8.4	9.5
Mechanical Time Constant (Non Brake)		ms	0.9	0.74	0.66	0.66	0.68	0.57	0.51
Mechanical Time Constant (Brake)		ms	1.05	0.82	0.72	0.72	0.76	0.61	0.54
Power Rate (Non Brake)		kW/s	51.6	79.9	110.6	136.6	118.1	127.7	200
Power Rate (Brake)		kW/s	44.4	72	101.7	127.8	106	119.3	186.8
Dielectric Withstand Voltage		-	AC1500V, 60s						
Input Voltage		VAC	AC 200						
Insulation Class		-	Class F						
Insulation Resistance		MΩ MIN	100 (at DC500V)						
Shaft Friction Torque		N·m Max	0.49		0.59		0.49		
		kgf·cm Max	5.0		6.0		5.0		
Allowable Thrust Shaft Load		N	98						
		kgf	10						
Allowable Radial Shaft Load		N	490						
		kgf	50						
Shaft End Play		mm Max	0.5						
Color		-	Black						
Weight (Non Brake)		kg	3.4	4.2	5	5.8	8.3	9.4	9.4
Weight (Brake)		kg	5.3	6.1	6.9	7.7	10.6	11.7	11.7

[Caution]

1. Suppose to attach Aluminum Heat Sink(305x305xT12mm) on Motor when using the rated torque. Ambient temperature should be below 40°C.
2. All values were measured between 20~30°C.
3. Each value is derived when the motor is used with matched drive.
4. Inertia, Rated Current, Instantaneous Maximum Current, Electrical Time Constant, Mechanical Time Constant, Power Rate, Shaft Friction Torque and Product weight might change by using Brake, Oil Seal Type.
5. Keep the temperature of motor's surface below 85°C.

CSMS Motor - Torque Speed Curves

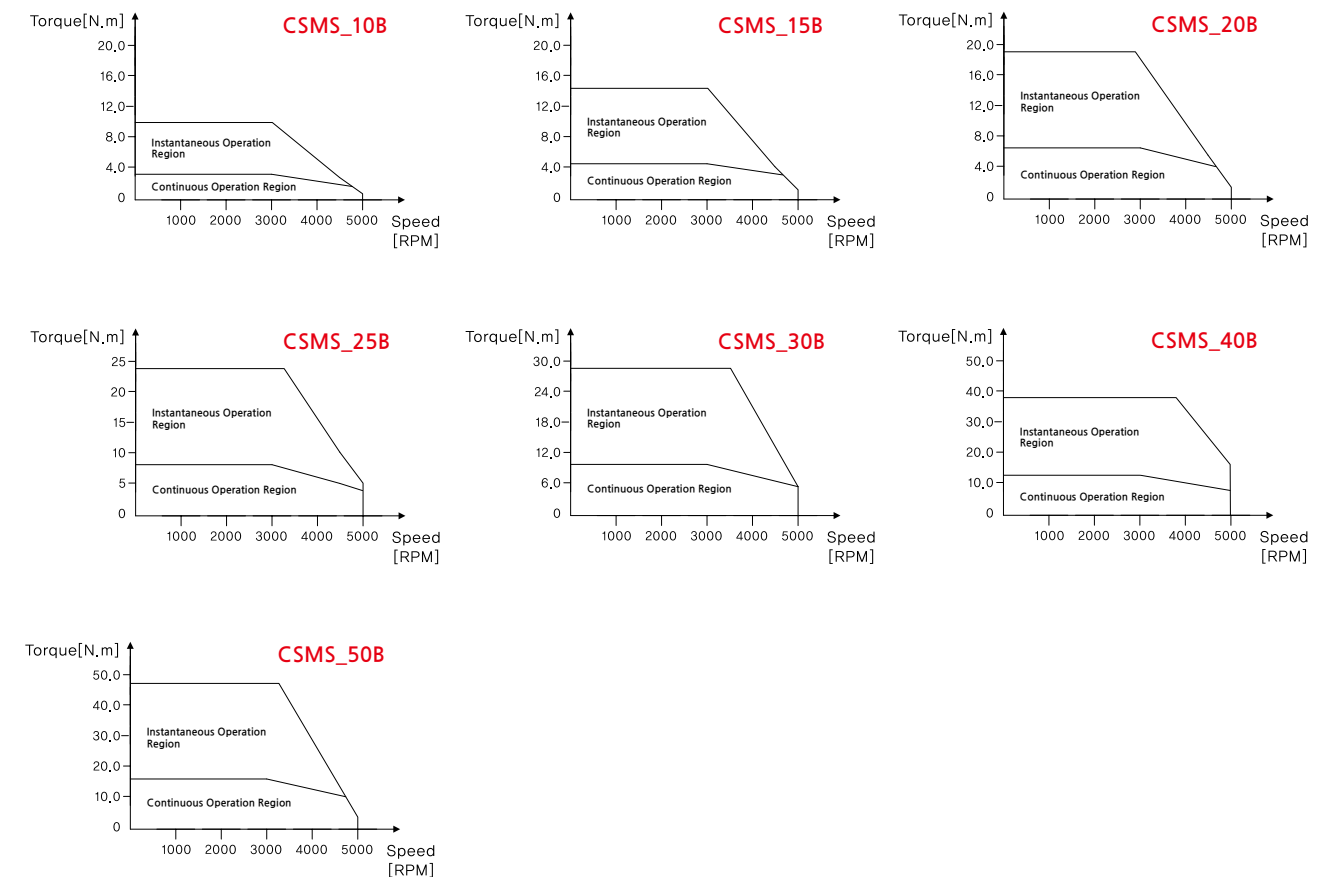

CSMS Motor - Holding Brake Specification

Item	Category	Unit	CSMS_						
			10B	15B	20B	25B	30B	40B	50B
Rated Voltage		VDC	DC 24V ±10%						
Static Friction Torque		N·m MIN (kgf·cm MIN)	8.0 (81.6)			12.5 (127.6)		17.0 (173.5)	
Power Consumption (20 °C)		W	12.8			22			
Moment of Rotor Inertia		[GD ² /4] kg·m ² x10 ⁻⁴ (gf·cm·s ²)	0.45 (0.46)			1.8 (1.8)			
Brake Absorbing Time		ms MAX	90			90			
Brake Releasing Time		ms MAX	20			40			

■ CSMS Motor - External Dimension outline

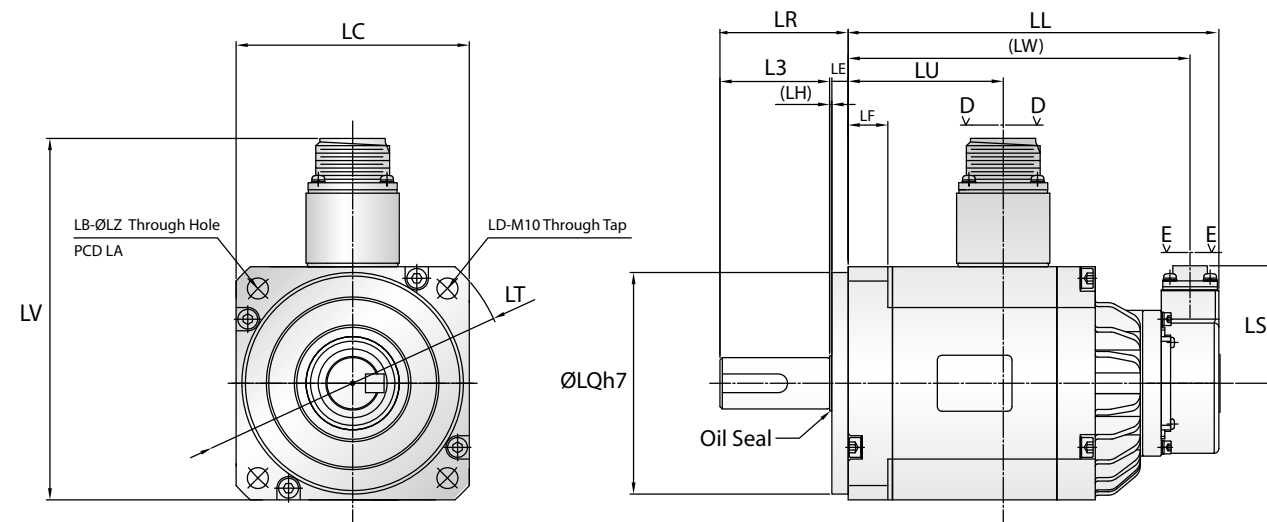

■ CSMS Motor - External Dimension

Item	Motor	Unit	CSMS_						
			10B	15B	20B	25B	30B	40B	50B
LL	Non Brake		159	174	189	204	172.5	200.5	200.5
	Brake		203	218	233	248	193.5	221.5	221.5
LW	Non Brake		146.6	161.6	176.6	191.6	160	188	188
	Brake		190.6	205.6	220.6	235.6	181	209	209
LU	Non Brake		58.5	73.5	88.5	103.5	104.5	132.5	132.5
	Brake		66.5	81.5	96.5	111.5	125.5	153.5	153.5
	LR		55	55	55	55	55	65	65
	L3		47	47	47	47	47	61	61
	LH		1	1	1	1	4	0	0
	LE		7	7	7	7	4	4	4
	LF		17	17	17	17	15	15	15
	LQ		95	95	95	95	110	110	110
	LS		50.4	50.4	50.4	50.4	50.5	50.5	50.5
	LC		100	100	100	100	130	130	130
	LV		150	150	150	150	185	185	185
	LT		133	133	133	133	164	164	164
	LB		4	4	4	4	2	2	2
	LZ		9	9	9	9	9	9	9
	LA		115	115	115	115	145	145	145
	LD		0	0	0	0	2	2	2

■ CSMS Motor - Shaft Dimension

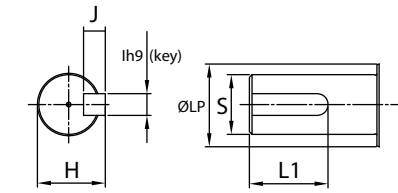

Item	Motor	CSMS_						
		10B	15B	20B	25B	30B	40B	50B
	LP	24	24	24	24	24	-	-
	S	19	19	19	19	22	24	24
	L1	45			45	55		
	lh9	6			8	8		
	J	6			7	7		
	H	21.5			25	27		

■ CSMS Motor - Connector Specification

Item	Category	Motor				Encoder	
Part no.	CSMS_				All Catalog		
	10B,15B,20B,25B		30B,40B,50B		All Catalog		
	N/MS3102A20-18P		N/MS3102A24-11P		JN2AS10ML2-R		
Pin spec.	Pin	Function	Pin no.	Function	Pin no.	Function	
	A	-	A	(Brake)	1	GND (0V)	
	B	W-phase	B	(Brake)	2	-	
	C	-	C	-	3	SD	
	D	-	D	U-phase	4	Vcc (+5V)	
	E	F.G	E	V-phase	5	BAT-	
	F	U-phase	F	W-phase	6	BAT+	
	G	(Brake)	G	F.G	7	/SD	
	H	(Brake)	H	-	8	-	
	I	V-phase	I	-	9	Shield	
	-	-	-	-	10	-	
Outline	 Viewed from D - D		 Viewed from D - D		 Viewed from E - E		

CSMD Motor

Basic Specifications

Item	Category	Unit	CSMD_							
			08B	10B	15B	20B	25B	30B	40B	50B
Flange Size	mm		130	130	130	130	130	130	180	180
Rated Output	kW		0.75	1.00	1.50	2.00	2.50	3.00	4.00	5.00
Rated Speed	r/min		2,000	2,000	2,000	2,000	2,000	2,000	2,000	2,000
Max. Speed	r/min		3,000	3,000	3,000	3,000	3,000	3,000	3,000	3,000
Rated Torque	N·m		3.6	4.8	7.2	9.6	11.9	14.3	19.1	23.9
	kgf·cm		36.5	48.7	72.9	97.4	121.4	145.9	194.9	243.9
Max. Instantaneous Torque	N·m		10.6	14.4	21.5	28.5	35.5	42.9	56.4	71.4
	kgf·cm		108.1	146.9	219.4	290.8	362.2	437.7	575.5	728.6
Rated Current	A(rms)		5.0	6.4	9.8	12.9	15.1	17.2	23.0	31.5
Max. Instantaneous Current	A(rms)		13.5	18.2	28.2	37.2	43.9	50.5	65.9	91.4
Rotor Moment of Inertia	$X10^{-4}kg\cdot m^2$		3.49	5.60	7.71	7.71	10.17	12.63	41.30	56.80
	gf·cm·sec ²		3.56	5.71	7.87	7.87	10.38	12.89	42.10	58.00
Rotor Moment of Inertia (Brake)	$X10^{-4}kg\cdot m^2$		4.37	6.49	8.59	8.59	11.05	13.52	43.10	58.70
	gf·cm·sec ²		4.46	6.62	8.77	8.77	11.28	13.80	44.00	59.90
Electrical Time Constant	ms		6.0	7.4	7.8	7.8	9.3	9.8	16.7	14.2
Mechanical Time Constant (Non Brake)	ms		1.07	0.75	0.66	0.66	0.53	0.49	0.58	0.54
Mechanical Time Constant (Brake)	ms		1.33	0.87	0.74	0.74	0.58	0.53	0.60	0.56
Power Rate (Non Brake)	kW/s		36.6	40.7	66.2	118.1	139.1	161.8	88.4	93.2
Power Rate (Brake)	kW/s		29.2	35.1	59.3	106.0	128.0	151.2	84.6	97.3
Dielectric Withstand Voltage	-		AC1500V, 60s							
Input Voltage	VAC		AC 200							
Insulation Class	-		Class F							
Insulation Resistance	MΩ MIN		100 (at DC500V)							
Shaft Friction Torque	N·m Max		0.49						0.98	
	kgf·cm Max		5						10	
Allowable Thrust Shaft Load	N		98						392	
	kgf		10						40	
Allowable Radial Shaft Load	N		490						784	
	kgf		50						80	
Shaft End Play	mm Max		0.5							
Color	-		Black							
Weight (Non Brake)	kg		6.50	7.40	8.30	8.30	8.90	9.40	14.50	20.00
Weight (Brake)	kg		8.80	9.70	10.60	10.60	11.20	11.70	20.50	26.00

[Caution]

1. Suppose to attach Aluminum Heat Sink(305x305xT12mm) on Motor when using the rated torque. Ambient temperature should be below 40°C.
2. All values were measured between 20~30°C.
3. Each value is derived when the motor is used with matched drive.
4. Inertia, Rated Current, Instantaneous Maximum Current, Electrical Time Constant, Mechanical Time Constant, Power Rate, Shaft Friction Torque and Product weight might change by using Brake, Oil Seal Type.
5. Keep the temperature of motor's surface below 85°C.

CSMD Motor - Torque Speed Curves

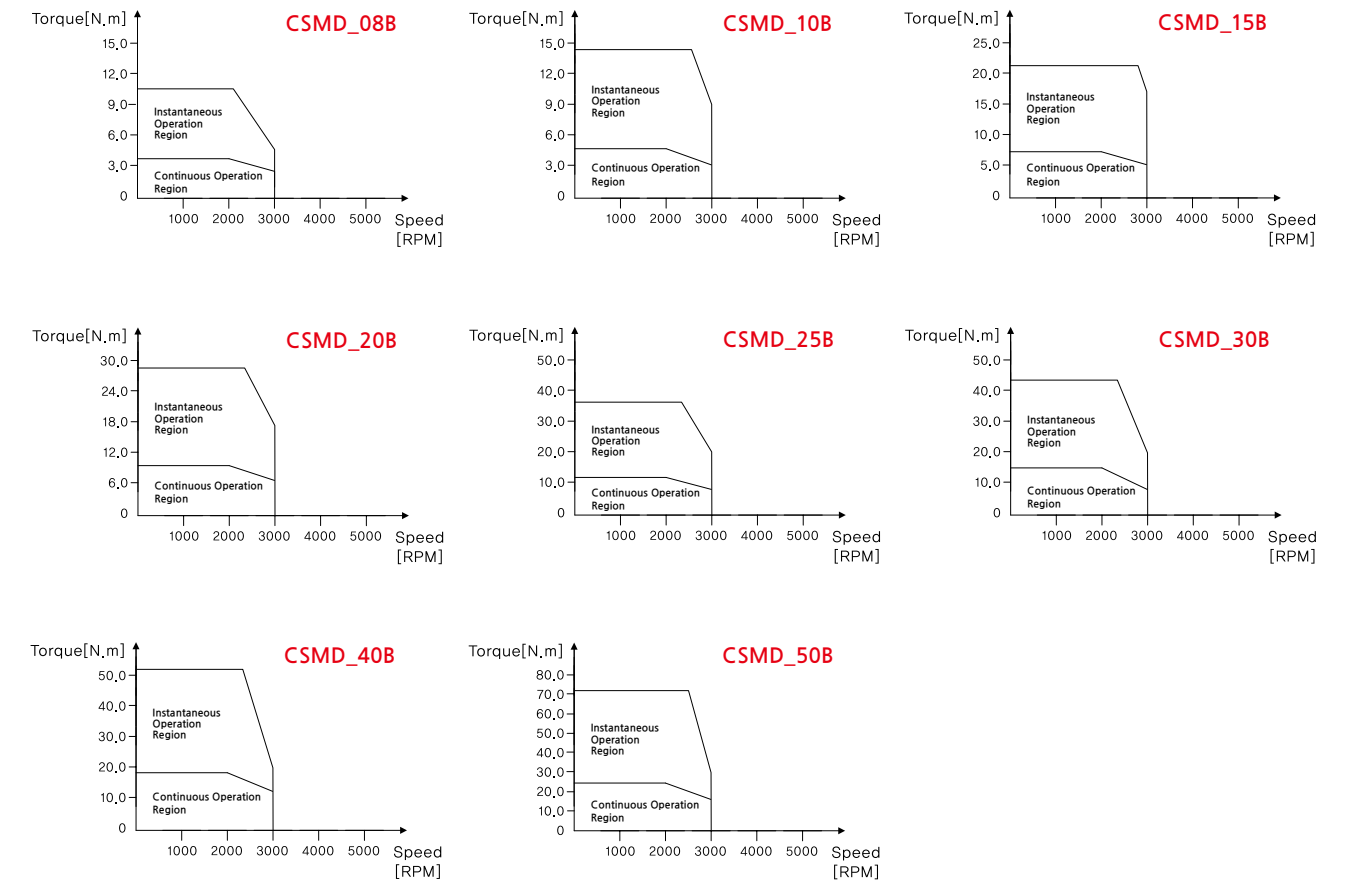

CSMD Motor - Holding Brake Specification

Item	Category	Unit	CSMD_							
			08B	10B	15B	20B	25B	30B	40B	50B
Rated Voltage	VDC		DC 24V ±10%							
Static Friction Torque	N·m MIN (kgf·cm MIN)		12.5 (127.6)				17.0 (173.5)		30.0 (306)	
Power Consumption (20 °C)	W		22						26	
Moment of Rotor Inertia	$[GD^2/4] kg\cdot m^2 \times 10^{-4}$ (gf·cm·s ²)		1.8 (1.8)						6.6 (6.7)	
Brake Absorbing Time	ms MAX		90						200	
Brake Releasing Time	ms MAX		40						100	

■ CSMD Motor - External Dimension outline

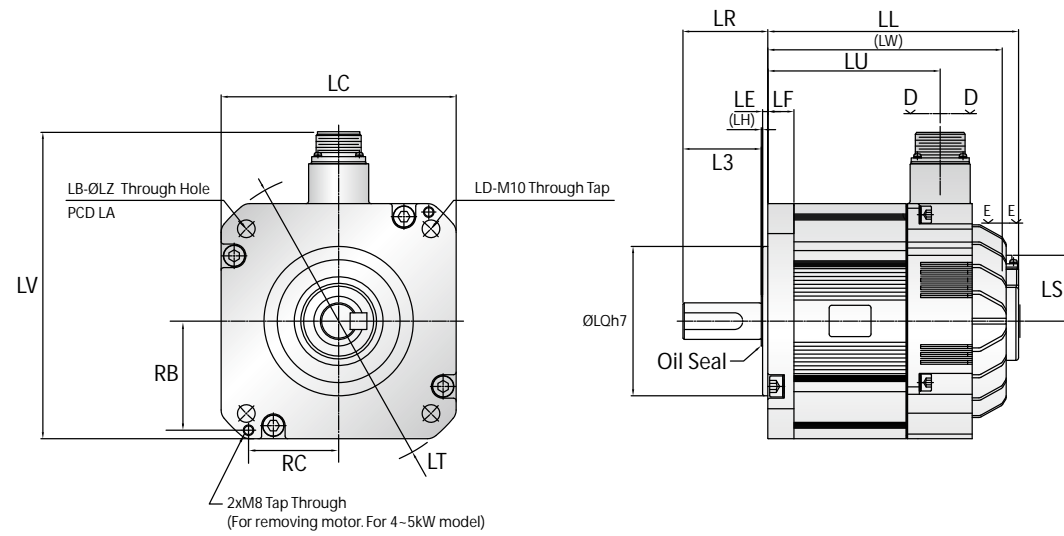

■ CSMD Motor - External Dimension

Item	Motor	Unit	CSMD_							
			08B	10B	15B	20B	25B	30B	40B	50B
LL	Non Brake		148.5	160.5	172.5	172.5	186.5	200.5	192	216
	Brake		169.5	181.5	193.5	193.5	207.5	221.5	223.5	247.5
LW	Non Brake		136	148	160	160	174	188	179.5	203.5
	Brake		157	169	181	181	195	209	211	235
LU	Non Brake		80.5	92.5	104.5	104.5	118.5	132.5	132	156
	Brake		101.5	113.5	125.5	125.5	139.5	153.5	163.5	187.5
	LR		55	55	55	55	65	65	65	70
	L3		47	47	47	47	61	61	60	65
	LH		4	4	4	4	0	0	1	1
	LE		4	4	4	4	4	4	4	4
	LF		15	15	15	15	15	15	20	20
	LQ		110	110	110	110	110	110	114.3	114.3
	LS		50.5	50.5	50.5	50.5	50.5	50.5	50.4	50.4
	LC		130	130	130	130	130	130	180	180
	LV		185	185	185	185	185	185.5	234.5	234.5
	LT		164	164	164	164	164	164	230	230
	LB		2	2	2	2	2	2	4	4
	LZ		9	9	9	9	9	9	13.5	13.5
	LA		145	145	145	145	145	145	200	200
	LD		2	2	2	2	2	2	0	0
	RB		-	-	-	-	-	-	83.5	83.5
	RC		-	-	-	-	-	-	69	69

■ CSMD Motor - Shaft Dimension

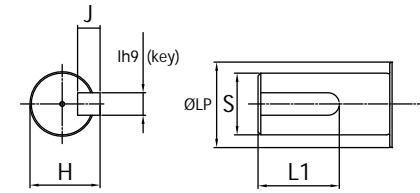

Item	Motor	CSMD_							
		08B	10B	15B	20B	25B	30B	40B	50B
LP		24	24	24	24	-	-	38	38
S		19	22	22	22	24	24	28	35
L1		45	45		55		55	55	
lh9		6	8		8		8	10	
J		6	7		7		7	8	
H		21.5	25		27		31	38	

■ CSMD Motor - Connector Specifications

Item	Category	Motor				Encoder	
Part no.		CSMD_				All Catalog	
		08B,10B,15B,20B,25B		30B,40B,50B			
		N/MS3102A20-18P		N/MS3102A24-11P		JN2AS10ML2-R	
Pin spec.	Pin no.	Function	Pin no.	Function	Pin no.	Function	
	A	-	A	(Brake)	1	GND (0V)	
	B	W-phase	B	(Brake)	2	-	
	C	-	C	-	3	SD	
	D	-	D	U-phase	4	Vcc (+5V)	
	E	F.G	E	V-phase	5	BAT-	
	F	U-phase	F	W-phase	6	BAT+	
	G	(Brake)	G	F.G	7	/SD	
	H	(Brake)	H	-	8	-	
	I	V-phase	I	-	9	Shield	
	-	-	-	10	-		
Outline		Viewed from D - D		Viewed from D - D		Viewed from E - E	

CSMH Motor

Basic Specifications

Item	Category	Unit	CSMH_						
			05B	10B	15B	20B	30B	40B	50B
Flange Size		mm	130	130	130	180	180	180	180
Rated Output		kW	0.5	1.0	1.5	2.0	3.0	4.0	5.0
Rated Speed		r/min	2,000	2,000	2,000	2,000	2,000	2,000	2,000
Max. Speed		r/min	3,000	3,000	3,000	3,000	3,000	3,000	3,000
Rated Torque		N·m	2.4	4.8	7.2	9.6	14.3	19.1	23.9
		kgf·cm	24.4	48.7	72.9	97.4	145.9	194.9	243.9
Max. Instantaneous Torque		N·m	6.0	14.4	21.5	28.5	42.9	56.4	71.4
		kgf·cm	61.2	146.9	219.4	290.8	437.8	575.5	728.6
Rated Current		A(rms)	3.4	6.4	9.8	13.3	17.5	23.0	31.5
Max. Instantaneous Current		A(rms)	7.6	18.2	28.2	37.3	50.4	65.9	91.4
Rotor Moment of Inertia		$\times 10^{-4} \text{kg}\cdot\text{m}^2$	12.63	26.1	42.7	61.70	92.50	115.80	170.10
		gf·cm·sec ²	12.89	26.60	43.60	63.00	94.40	118.20	173.60
Rotor Moment of Inertia (Brake)		$\times 10^{-4} \text{kg}\cdot\text{m}^2$	13.52	27.00	43.60	63.90	94.40	117.70	172.00
		gf·cm·sec ²	13.8	27.5	44.5	65.0	96.3	120.1	175.5
Electrical Time Constant		ms	9.8	7.4	7.8	15.6	16.7	16.7	14.2
Mechanical Time Constant (Non Brake)		ms	0.49	3.50	3.68	0.87	1.29	1.62	1.63
Mechanical Time Constant (Brake)		ms	0.53	3.62	3.75	0.90	1.32	1.64	1.65
Power Rate (Non Brake)		kW/s	4.53	8.74	11.90	14.80	22.10	31.50	33.60
Power Rate (Brake)		kW/s	4.23	8.45	11.70	14.30	21.70	31.00	33.20
Dielectric Withstand Voltage		-	AC1500V, 60s						
Input Voltage		VAC	AC 200						
Insulation Class		-	Class F						
Insulation Resistance		MΩ MIN	100 (at DC500V)						
Shaft Friction Torque		N·m Max	0.49			0.98			
		kgf·cm Max	5			10			
Allowable Thrust Shaft Load		N	98			392			
		kgf	10			40			
Allowable Radial Shaft Load		N	490			784			
		kgf	50			80			
Shaft End Play		mm Max	0.5						
Color		-	Black						
Weight (Non Brake)		kg	9.4	9.2	11.1	18.0	20.0	21.0	24.8
Weight (Brake)		kg	11.7	11.5	13.4	24.5	26.5	27.5	30.8

[Caution]

1. Suppose to attach Aluminum Heat Sink(305x305xT12mm) on Motor when using the rated torque. Ambient temperature should be below 40°C.
2. All values were measured between 20~30°C.
3. Each value is derived when the motor is used with matched drive.
4. Inertia, Rated Current, Instantaneous Maximum Current, Electrical Time Constant, Mechanical Time Constant, Power Rate, Shaft Friction Torque and Product weight might change by using Brake, Oil Seal Type.
5. Keep the temperature of motor's surface below 85°C.

CSMH Motor - Torque Speed Curves

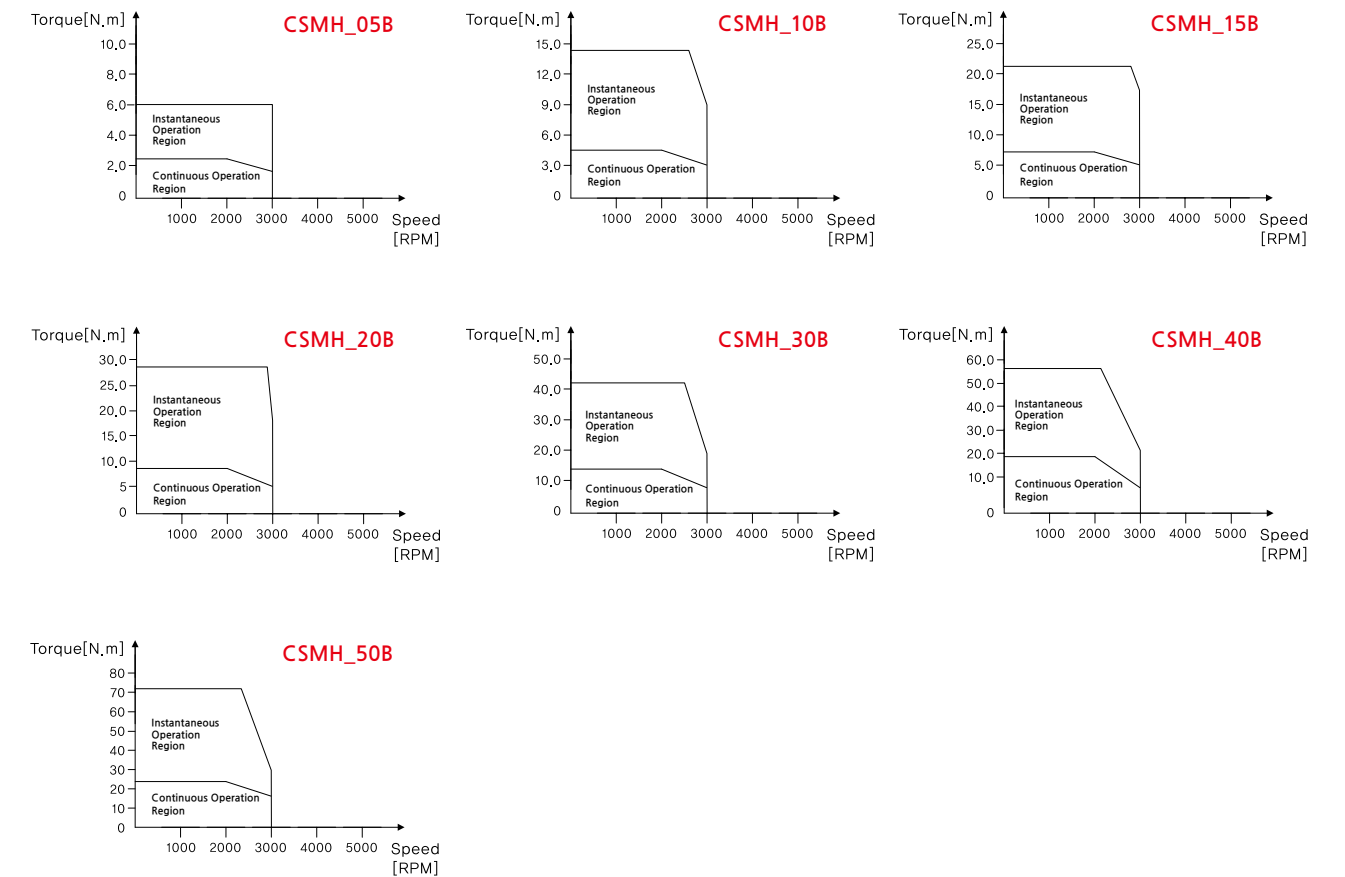

CSMH Motor - Holding Brake Specification

Item	Category	Unit	CSMH_						
			05B	10B	15B	20B	30B	40B	50B
Rated Voltage		VDC	DC 24V ±10%						
Static Friction Torque		N·m MIN (kgf·cm MIN)	12.5 (127.6)			30.0 (306)			
Power Consumption (20 °C)		W	22			26			
Moment of Rotor Inertia		$[\text{GD}^2/4] \text{kg}\cdot\text{m}^2 \times 10^{-4}$ (gf·cm·s ²)	1.8 (1.8)			6.6 (6.7)			
Brake Absorbing Time		ms MAX	90			200			
Brake Releasing Time		ms MAX	40			100			

■ CSMH Motor - External Dimension outline

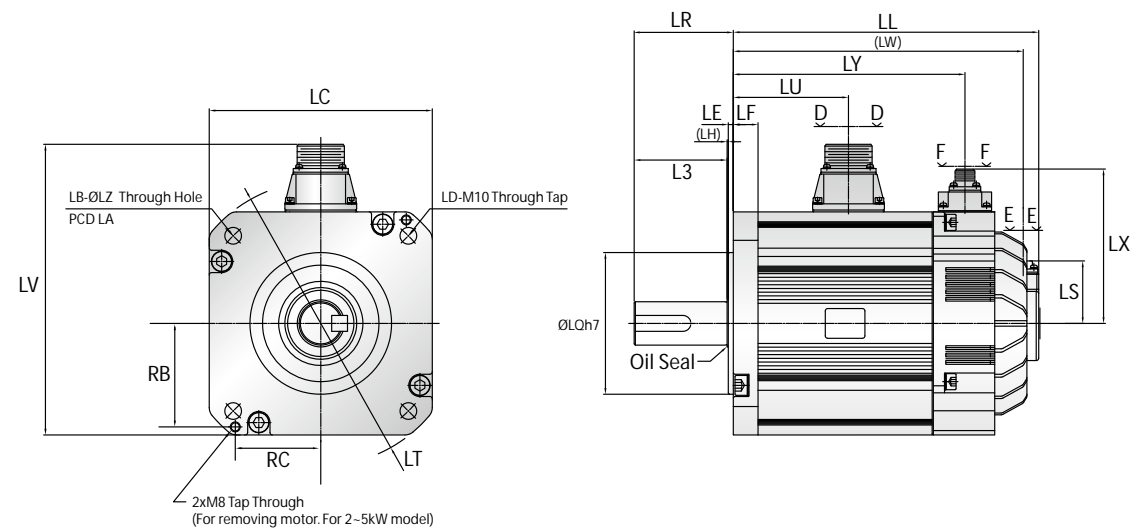

■ CSMH Motor - External Dimension

Item	Motor	Unit	CSMH_						
			05B	10B	15B	20B	30B	40B	50B
LL	Non Brake		200.5	182.5	197.5	210	221	227	253
	Brake		221.5	232.5	247	246.5	249.5	263.5	297.5
LW	Non Brake		188	170	185	197.5	208.5	214.5	240.5
	Brake		209	220	234.5	234	237	251	285
	LY		-	163	178	187	190	204	238
LU	Non Brake		132.5	69	81	88	99	99	123
	Brake		153.5	69	81	93	99	99	123
	LR		70	70	70	80	80	80	80
	L3		62	62	62	75	75	75	75
	LH		4	4	4	1	1	1	1
	LE		4	4	4	4	4	4	4
	LF		15	15	15	20	20	20	20
	LQ		110	110	110	114.3	114.3	114.3	114.3
	LS		50.5	50.5	50.5	50.4	50.4	50.4	50.4
	LC		130	130	130	180	180	180	180
	LV		185	185	185	234.5	234.5	234.5	234.5
	LT		164	164	164	230	230	230	230
	LB		2	2	2	4	4	4	4
	LZ		9	9	9	13.5	13.5	13.5	13.5
	LA		145	145	145	200	200	200	200
	LD		2	2	2	0	0	0	0
	RB		-	-	-	83.5	83.5	83.5	83.5
	RC		-	-	-	69	69	69	69

■ CSMH Motor - Shaft Dimension

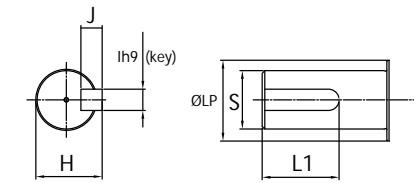

Item	Motor	CSMH_						
		05B	10B	15B	20B	30B	40B	50B
	LP	24	24	24	38	38	38	38
	S	22	22	22	35	35	35	35
	L1	45			55			
	lh9	8			10			
	J	7			8			
	H	25			38			

■ CSMH Motor - Connector Specifications

Item	Category	Motor				Encoder		Brake	
		CSMH_		CSMH_		All Catalog		CSMH_	
Part no.		05B · 10B · 15B		20B · 30B · 40B · 50B		All Catalog		CSMH_	
		N/MS3102A20-18P		N/MS3102A24-11P		JN2AS10ML2-R		05B	10B · 15B · 20B · 30B · 40B · 50B
Pin spec.		Pin no.	Function	Pin no.	Function	Pin no.	Function	Pin no.	Function
		A	-	A	-	1	GND (0V)	A	Brake
		B	W-phase	B	-	2	-	B	Brake
		C	-	C	-	3	SD		
		D	-	D	U-phase	4	Vcc (+5V)		
		E	F.G	E	V-phase	5	BAT-		
		F	U-phase	F	W-phase	6	BAT+		
		G	(Brake)	G	F.G	7	/SD		
		H	(Brake)	H	-	8	-		
		I	V-phase	I	-	9	Shield		
		-	-	-	-	10	-		
Outline		Viewed from D - D		Viewed from D - D		Viewed from E - E		Viewed from F - F	

RSMZ Motor

Basic Specifications

Item \ Category	Unit	RSMZ_							
		A5B	01B	02B	04B	06B	08B	10B	
Flange Size	mm	40	40	60	60	80	80	80	
Rated Output	W	50	100	200	400	600	750	950	
Rated Speed	r/min	3000							
Max. Speed	r/min	5000				4500		3500	
Rated Torque	N·m	0.16	0.32	0.64	1.3	1.91	2.4	3	
	kgf·cm	1.62	3.24	6.5	13	19.49	24.3	30.9	
Max. Instantaneous Torque	N·m	0.48	0.95	1.91	3.8	5.73	7.1	9.1	
	kgf·cm	4.9	9.7	19.5	39	58.47	73	92.6	
Rated Current	A(rms)	1	1	1.6	2.5	4.1	4.3	4.3	
Max. Instantaneous Current	A(rms)	3.04	3.04	4.87	7.43	12.31	12.94	12.94	
Rotor Moment of Inertia (Non Brake) 2500P/R. / 17bit.	X10 ⁻⁴ kg·m ²	0.030/0.024	0.059/0.054	0.19/0.18	0.34/0.33	0.93/0.92	1.2	1.47	
	gf·cm·sec ²	0.031/0.024	0.060/0.055	0.19/0.18	0.35/0.34	0.95/0.94	1.22	1.5	
Rotor Moment of Inertia (Brake) 2500P/R. / 17bit.	X10 ⁻⁴ kg·m ²	0.034/0.029	0.061/0.056	0.21/0.20	0.36/0.35	1.05/1.04	1.32	1.49	
	gf·cm·sec ²	0.035/0.030	0.062/0.057	0.21/0.20	0.37/0.36	1.07/1.06	1.35	1.52	
Electrical Time Constant	ms	0.67	0.88	3.4	3.5	7.3	7.4	7.6	
Mechanical Time Constant (Non Brake) 2500P/R. / 17bit	ms	1.58/1.3	0.90/0.82	0.84/0.79	0.59/0.57	0.4/0.39	0.44	0.33	
Mechanical Time Constant (Brake) 2500P/R. / 17bit	ms	1.80/1.5	0.93/0.85	0.92/0.88	0.63/0.61	0.45/0.44	0.5	0.34	
Power Rate (Non Brake)	kW/s	8.7/10.9	17.7/19.4	21.8/23.0	48.7/50.2	39.2/39.7	48.3	62.2	
Power Rate (Brake)	kW/s (Brake)	7.7/8.9	17.1/18.7	19.7/20.7	46.0/47.4	34.7/35.1	43.9	61.4	
Poles	poles	8							
Input Voltage	VAC	200/200							
Insulation Class	-	Class B							
Vibration	-	V-15							
Shaft End Play	mm Max	0.5							
Allowable Radial Shaft Load	N	68	68	245	245	392	392	392	
Allowable Thrust Shaft Load	N	58	58	98	98	147	147	147	
Color	-	Black							
Weight (Non Brake)	kg	0.39	0.66	1	1.7	2.9	3.5	4.1	
Weight (Brake)	kg	0.63	0.93	1.5	2.3	3.5	4.3	4.9	

[Caution]

1. The above characteristics are typical characteristics when driving a sinusoidal wave. (Mid-value 20°C)
2. The surface temperature of the motor should be below 65°C.
3. Inertia, rated current, Max. instantaneous current, electrical time constant, mechanical time constant, power rate, product weight, etc might be changed in case of using brake type and oil seal type.

RSMZ Motor - Torque Speed Curves

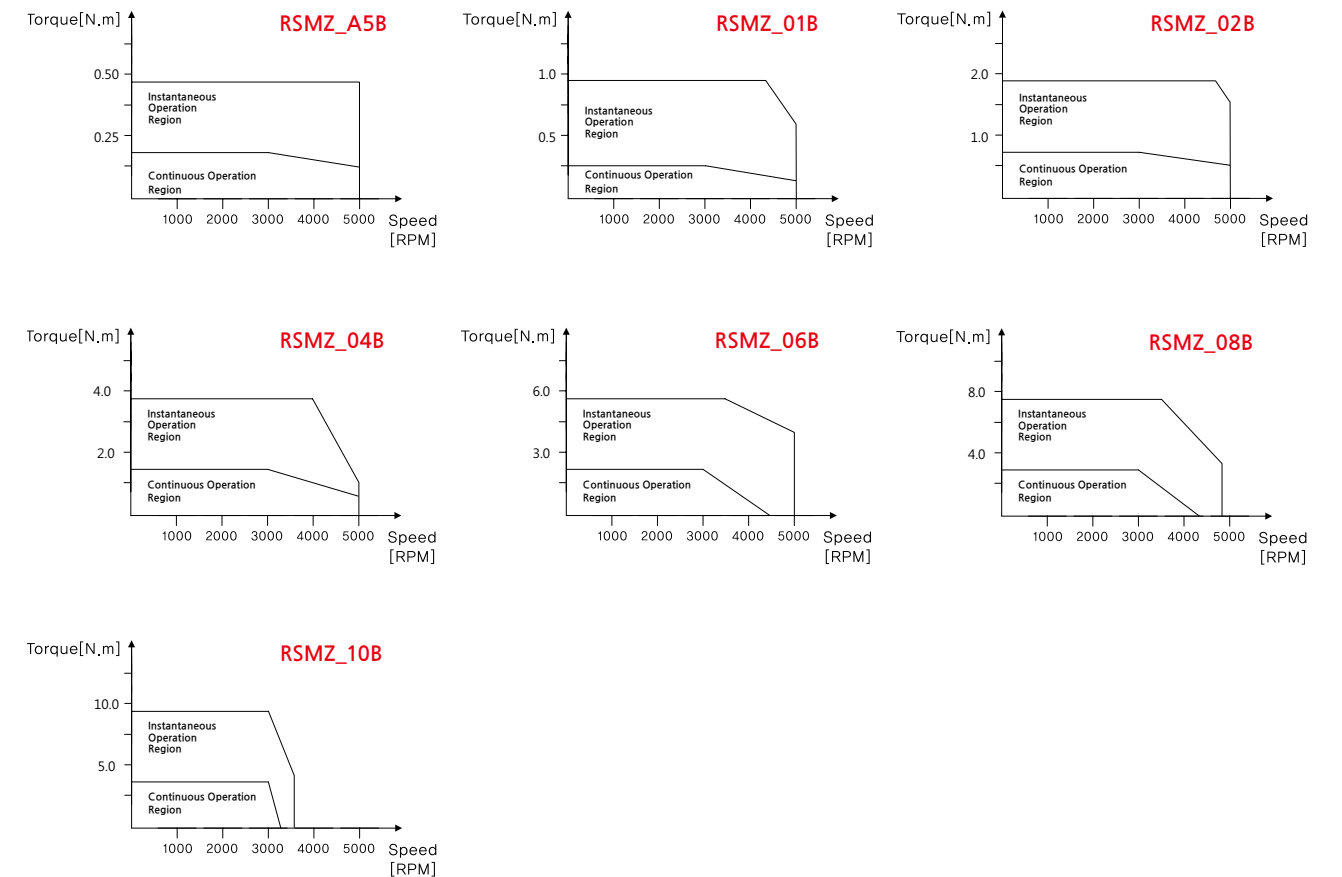

RSMZ Motor - Holding Brake Specifications

Item \ Category	Unit	RSMZ_							
		A5B	01B	02B	04B	06B	08B	10B	
Raged Voltage	VDC	DC 24V ±10%							
Static Friction Torque	N·m	0.39		1.69		3.25			
Rotor Moment of Inertia	10 ⁻⁴ kg·m ²	0.0025		0.02		0.075			
Brake Absorbing Time	ms	25		50		60			
Brake Releasing Time	ms	20		15		15			

■ RSMZ Motor - External Dimension Outline

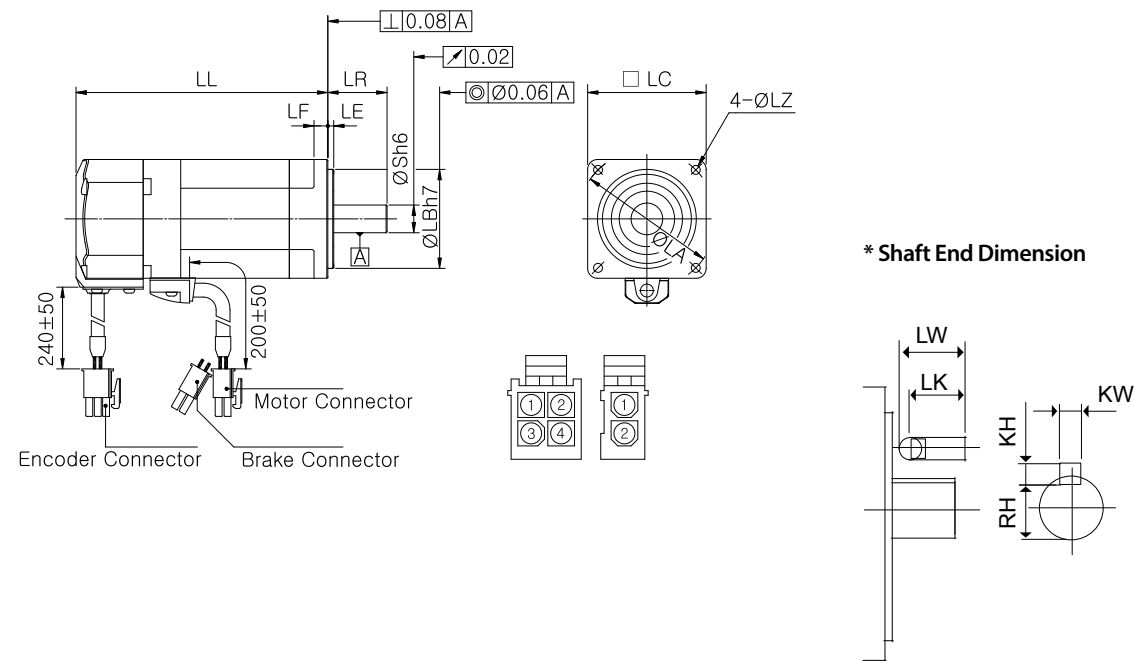

■ RSMZ Motor - External Dimension

Item	Category	RSMZ_													
		A5B		01B		02B		04B		06B		08B		10B	
		ABS	INC	ABS	INC	ABS	INC	ABS	INC	ABS	INC	ABS	INC	ABS	INC
LL	Non Brake	81.5	68	111.5	98	98	84.5	127.5	114	128	115	146	133	164	151
	Brake	112.5	100	142.5	130	130.5	118	160	147.5	163	150	181	168	199	186
	LR	25	25	30	30	35	35	35	35	35	35	35	35	35	35
	S	8	8	11	14	16	19	19	19	19	19	19	19	19	19
	LA	45	45	70	70	90	90	90	90	90	90	90	90	90	90
	LB	30	30	50	50	70	70	70	70	70	70	70	70	70	70
	LC	40	40	60	60	80	80	80	80	80	80	80	80	80	80
	LE	3	3	3	3	3	3	3	3	3	3	3	3	3	3
	LF	6	6	7	7	8	8	8	8	8	8	8	8	8	8
	LZ	3.6	3.6	5.5	5.5	6.6	6.6	6.6	6.6	6.6	6.6	6.6	6.6	6.6	6.6

■ RSMZ Motor - Shaft End Dimension

Item	Category	RSMZ_							
		A5B	01B	02B	04B	06B	08B	10B	
	LK / LW / LN (D-cut)	14	14	20	25	25	25	25	
	LK	12.5	12.5	18	22.5	22	22	22	
	KW	3h9	3h9	4h9	5h9	6h9	6h9	6h9	
	KH	3	3	4	5	6	6	6	
	RH / LP (D-cut)	6.2	6.2	8.5	11	12.5	15.5	15.5	

■ RSMZ Motor - Connector Specifications

Item	Category	Motor		Brake		Encoder			
		Part no.	Function	Part no.	Function	Part no.	Function	Function	
Pin spec.	Pin no.	172167-1(AMP)	U	172165-1(AMP)	Brake	172169-1 (AMP)	BAT+	A	
			V		Brake	770835-1	BAT-	/A	
			W				3	FG	B
			FG				4	SD	/B
							5	/SD	Z
							6	-	/Z
							7	VCC (+5V)	VCC (+5V)
							8	GND (0V)	GND (0V)
							9	-	FG
		Outline							

RSMS Motor

Basic Specifications

Item	Category	Unit	RSMS_								
			10B	15B	20B	25B	30B	35B	40B	45B	50B
Flange Size	mm		100	100	100	100	120	120	130	130	130
Rated Output	kW		1	1.5	2	2.5	3	3.5	4	4.5	5
Rated Speed	r/min		3000								
Max. Speed	r/min		5000				4500				
Rated Torque	N·m		3.18	4.77	6.37	7.96	9.54	11.14	12.7	14.3	15.9
	kgf·cm		32.45	48.7	65	81.2	97.35	113.7	130	146	162
Max. Instantaneous Torque	N·m		9.5	14.5	19.24	23.8	28.59	33.3	37.9	42.9	47.6
	kgf·cm		96.94	148	196.3	242.9	291.7	339.8	387	438	486
Rated Current	A(rms)		7.2	9.4	13	15.9	20	21.6	24.7	29	28.5
Rated Current	A(rms)		21.00	28.30	39.60	48.10	56.29	61.00	74.26	83.45	84.87
Rotor Moment of Inertia (Non Brake)	$10^{-4}kg\cdot m^2$		2.06	2.39	3.04	3.78	5.99	6.93	12.4	13.6	16
	gf·cm·sec ²		2.1	2.44	3.1	3.86	6.11	7.07	12.7	13.9	16.3
Rotor Moment of Inertia (Brake)	$10^{-4}kg\cdot m^2$		2.5	2.84	3.49	4.23	6.44	7.38	13.7	14.0	17.3
	gf·cm·sec ²		2.55	2.9	3.56	4.32	6.57	7.53	14	15.2	17.7
Electrical Time Constant	ms		9.19	10.49	11.17	11.1	16.35	20.2	20	25.7	20
Mechanical Time Constant (Non Brake)	ms		0.87	0.54	0.53	0.52	0.42	0.38	0.58	0.45	0.48
Mechanical Time Constant (Brake)	ms		1.05	0.64	0.6	0.59	0.44	0.41	0.64	0.49	0.52
Power Rate (Non Brake)	kW/s		50.08	97.21	136.29	171.16	155.1	183	134	154	161
Power Rate (Brake)	kW/s		41.3	81.81	118.72	152.95	144.3	172	121	140	149
Poles	poles		8								
Input Voltage	VAC		200/220								
Insulation Class	-		F								
Vibration	-		V-15								
Allowable Radial Shaft Load	N		490	490	490	490	784	784	784	784	784
Allowable Thrust Shaft Load	N		196	196	196	196	343	343	343	343	343
Color	-		Black								
Weight (Non Brake)	kg		4.5	5.1	6.5	7.5	9.3	10.9	12.9	15.1	17.3
Weight (Brake)	kg		5.1	6.4	7.8	8.8	10.6	12.2	14.8	17	19.2

[Caution]

1. The above characteristics are typical characteristics when driving a sinusoidal wave. (Mid-value 20°C)
2. The surface temperature of the motor should be below 65°C.
3. Inertia, rated current, Max. instantaneous current, electrical time constant, mechanical time constant, power rate, product weight, etc might be changed in case of using brake type and oil seal type.

RSMS Motor - Torque Speed Curves

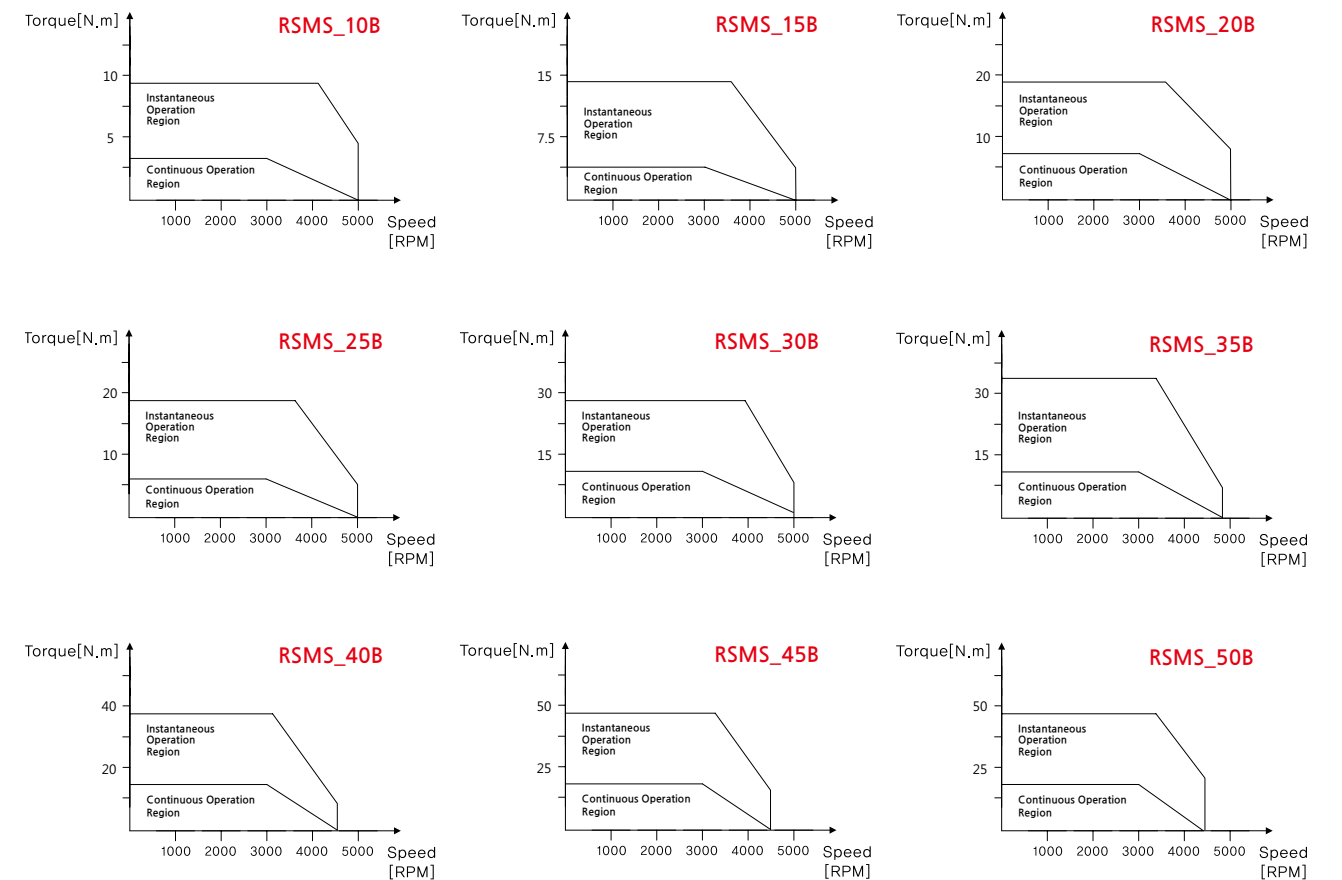

RSMS Motor - Holding Brake Specifications

Item	Category	Unit	RSMS_							
			10B	15B	20B	25B	30B	35B	40B	45B
Raged Voltage	VDC		DC 24V ±10%							
Static Friction Torque	N·m		12				16.5			
Rotor Moment of Inertia	$10^{-4}kg\cdot m^2$		0.45				1.2			
Brake Absorbing Time	ms		100				110			
Brake Releasing Time	ms		20				50			

■ RSMS Motor - External Dimension Outline

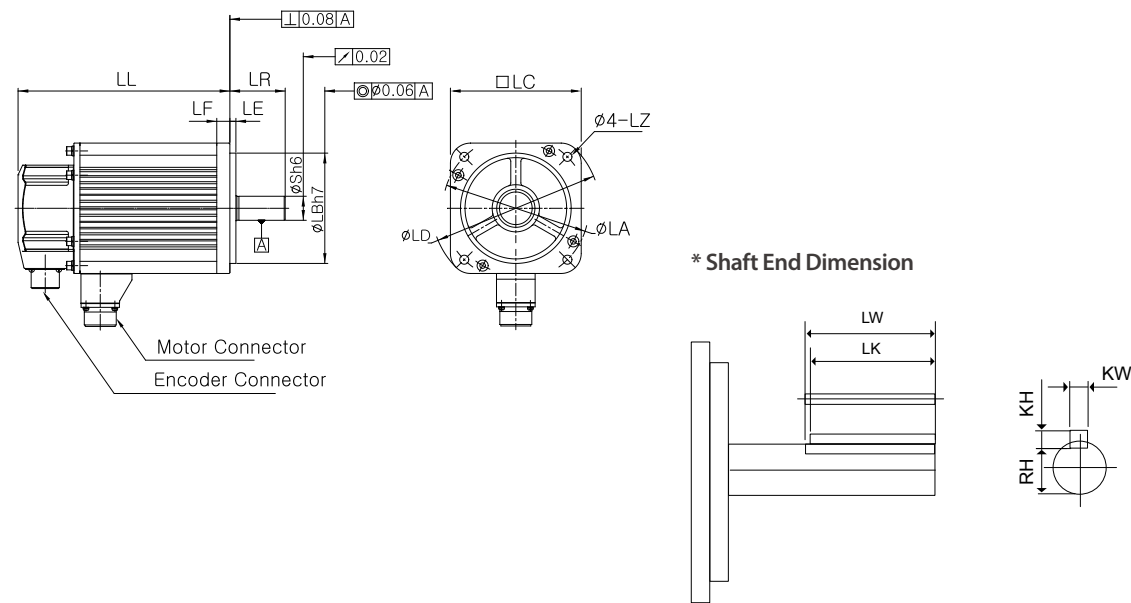

■ RSMS Motor - External Dimension

Item	Category	RSMS_								
		10B	15B	20B	25B	30B	35B	40B	45B	50B
LL	Non Brake	162.5	187.5	210.5	235.5	214.5	234.5	248	268	288
	Brake	182.5	207.5	230.5	255.5	239.5	259.5	273	293	313
LR		55	55	55	55	55	55	65	65	65
S		19	19	19	19	22	22	24	24	24
LA		115	115	115	115	130/145	130/145	145	145	145
LB		95	95	95	95	110	110	110	110	110
LC		100	100	100	100	120	120	130	130	130
LD		135	135	135	135	162	162	165	165	165
LE		3	3	3	3	3	3	6	6	6
LF		10	10	10	10	12	12	12	12	12
LZ		9	9	9	9	9	9	9	9	9

■ RSMS Motor - Shaft End Dimension

Item	Category	RSMS_		
		10B~25B	30B~35B	40B~50B
LW		45	45	55
LK		42	41	51
KW		6h9	8h9	8h9
KH		6	7	7
RH		15.5	18	20

■ RSMS Motor - Connector Specifications

Item	Category	Motor				Encoder				
		RSMS_		RSMS_		Whole capacity				
Part no.		10B ~ 25B	30B ~ 50B	10B ~ 25B	30B ~ 50B	MS3102A 20-29P				
		MS 3102A 20-4P	MS 3102A 22-22P	MS 3102A 20-18P	MS 3102A 24-11P					
Pin spec.		Pin no.	Function	Pin no.	Function	Pin no.	Function (17bit)	Pin no.	Function (2500ppr)	
		A	U	G	A	Brake	G	GND (0V)	A	A
		B	V	H	B	Brake	H	VCC (+5V)	B	/A
		C	W	A	C		J	FG	C	B
		D	FG	F	D	U	K	SD	D	/B
				I	E	V	L	/SD	E	Z
				B	F	W	S	BAT-	F	/Z
				E	G	FG	T	BAT+	G	GND (0V)
				D	H	FG			H	VCC (+5V)
				C	I				J	FG
Outline		MS 3102A 20-4P, 22-22P		MS 3102A 20-18P		MS 3102A 24-11P		MS 3102A 20-29P		

RSMD Motor

Basic Specifications

Item	Category	Unit	RSMD_									
			08B	10B	15B	20B	25B	30B	35B	40B	45B	50B
Flange Size	mm		120	130	130	130	130	130	180	180	180	180
Rated Output	kW		0.75	1	1.5	2	2.5	3	3.5	4	4.5	5
Rated Speed	r/min		2000									
Max. Speed	r/min		3000									
Rated Torque	N·m		3.58	4.77	7.15	9.55	11.9	14.3	16.7	19.1	21.5	23.9
	kgf·cm		36.5	48.6	72.9	97.4	121	146	170.4	195	219	244
Max. Instantaneous Torque	N·m		10.85	14.4	21.5	28.5	35.5	42.9	50	56.4	64.3	71.4
	kgf·cm		110.7	147	219.2	292	363	437	510.2	576	657	729
Rated Current	A(rms)		5	5.8	9.4	12.3	14	17.8	19.6	23.4	26.2	28
Max. Instantaneous Current	A(rms)		14.99	16.97	28.29	36.78	42.43	53.75	56.08	70.72	78.50	84.87
Rotor Moment of Inertia (Non Brake)	$\times 10^{-4} \text{kg}\cdot\text{m}^2$		2.67	4.82	7	9.3	11.5	13.8	31.49	33.5	37.7	45.5
	gf·cm·sec ²		2.72	4.92	7.1	9.5	11.7	14.1	32.13	34.2	38.5	46.4
Rotor Moment of Inertia (Brake)	$\times 10^{-4} \text{kg}\cdot\text{m}^2$		3.12	6.1	8.3	10.5	12.8	15	36.19	38.7	42.9	50.7
	gf·cm·sec ²		3.18	6.2	8.5	10.7	13.1	15.3	36.93	39.5	43.8	51.7
Electrical Time Constant	ms		15.76	18	22	21	21	20	28.27	28	30	32
Mechanical Time Constant (Non Brake)	ms		0.56	0.62	0.59	0.53	0.5	0.48	0.84	0.83	0.8	0.74
Mechanical Time Constant (Brake)	ms		0.65	0.78	0.697	0.6	0.56	0.52	0.97	0.96	0.9	0.83
Power Rate (Non Brake)	kW/s		49.1	48.8	74.6	100	124.9	151.2	90.66	111	124.8	128.3
Power Rate (Brake)	kW/s		41.94	38.6	62.9	88.6	112.2	139.4	78.9	96	109.6	115.2
Poles	poles		8									
Input Voltage	VAC		220/220									
Insulation Class	-		F									
Vibration	-		V-15									
Allowable Radial Shaft Load	N		392	490	490	490	784	784	784	784	784	784
Allowable Thrust Shaft Load	N		147	196	196	196	343	343	343	343	343	343
Color	-		Black									
Weight (Non Brake)	kg		4.8	6.8	8.5	10.6	12.8	14.6	16.2	19.75	21.5	25
Weight (Brake)	kg		6.1	8.7	10.1	12.5	14.7	16.5	18.7	23.25	25	28.5

[Caution]

- The above characteristics are typical characteristics when driving a sinusoidal wave. (Mid-value 20°C)
- The surface temperature of the motor should be below 65°C.
- Inertia, rated current, Max. instantaneous current, electrical time constant, mechanical time constant, power rate, product weight, etc might be changed in case of using brake type and oil seal type.

RSMD Motor - Torque Speed Curves

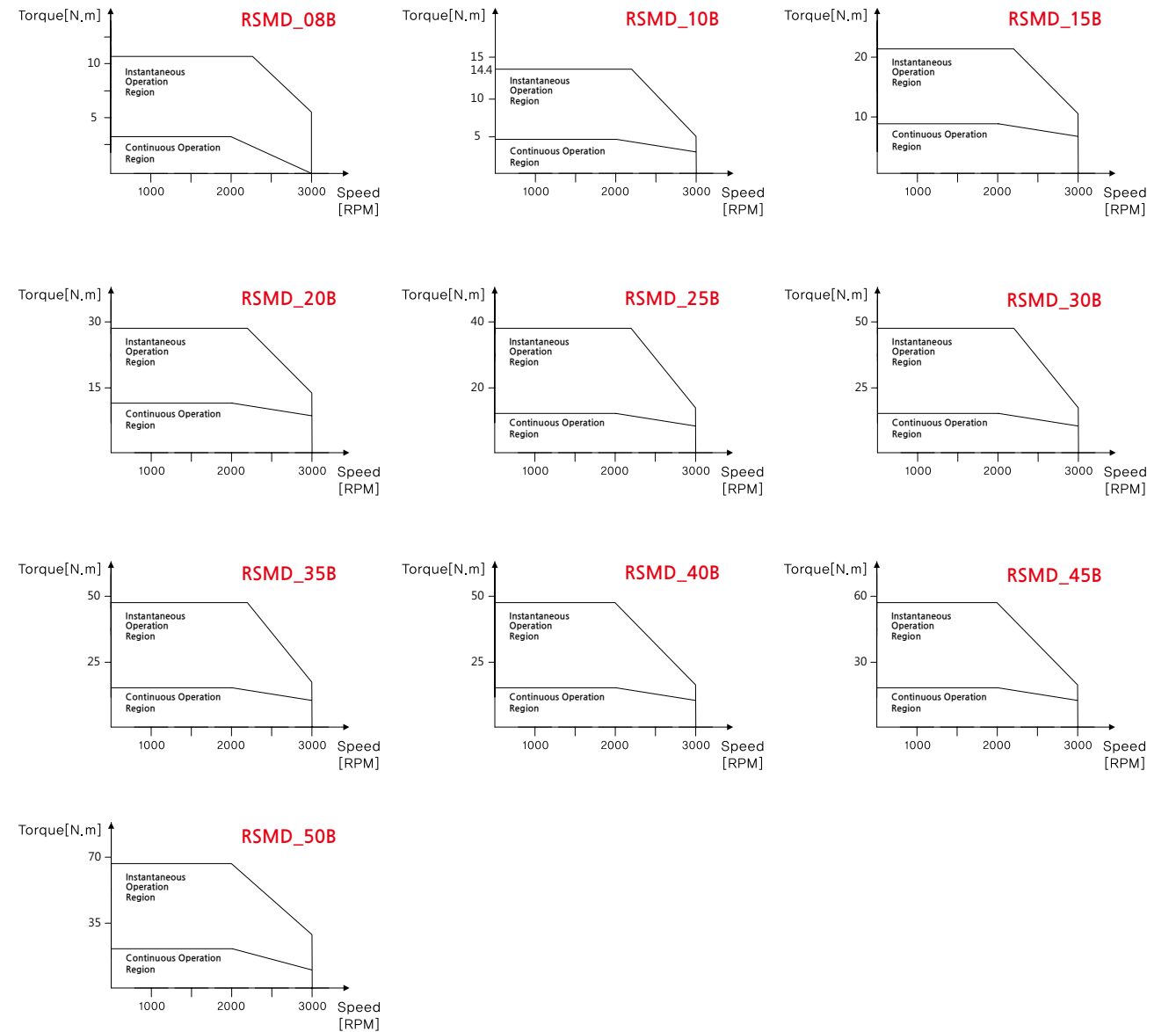

RSMD Motor - Holding Brake Specifications

Item	Category	Unit	RSMD_									
			08B	10B	15B	20B	25B	30B	35B	40B	45B	50B
Raged Voltage	VDC		DC 24V ±10%									
Static Friction Torque	N·m		12			16.5					25	
Rotor Moment of Inertia	$10^{-4} \text{kg}\cdot\text{m}^2$		0.45			1.2				4.7		
Brake Absorbing Time	ms		100			110				160		
Brake Releasing Time	ms		20			50				75		

■ RSMD Motor - External Dimension Outline

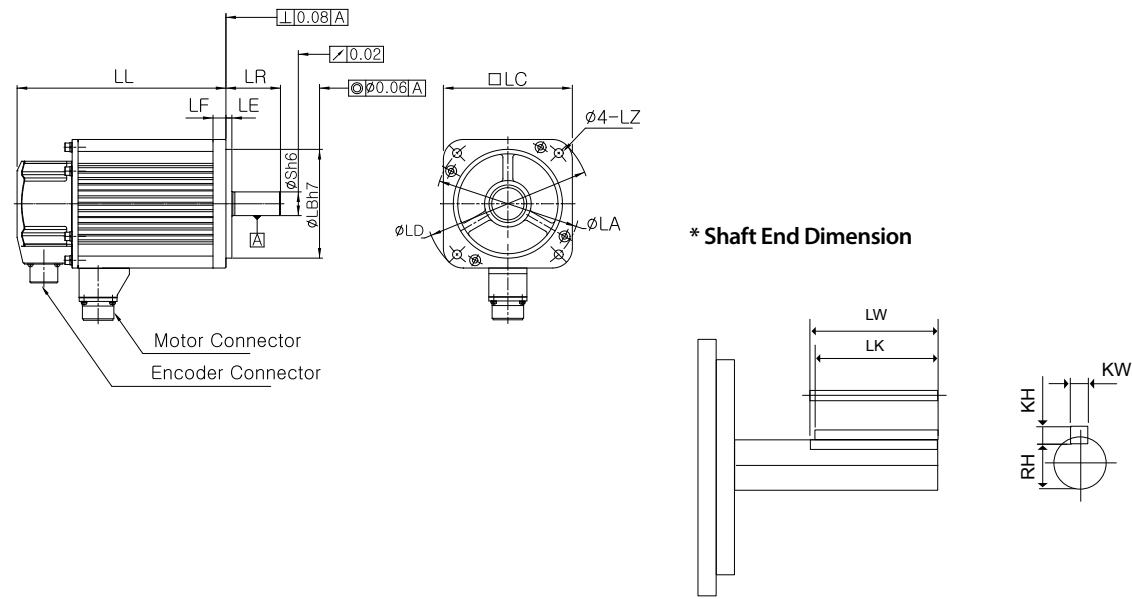

■ RSMD Motor - External Dimension

Item	Category	RSMD_									
		08B	10B	15B	20B	25B	30B	35B	40B	45B	50B
LL	Non Brake	144.5	158	183	208	233	258	198	203	213	233
	Brake	169.5	183	208	233	258	283	223	228	238	258
	LR	55	55	55	55	65	65	65	65	70	70
	S	19	22	22	22	24	24	28	28	35	35
	LA	130/145	145	145	145	145	145	200	200	200	200
	LB	110	110	110	110	110	110	114.3	114.3	114.3	114.3
	LC	120	130	130	130	130	130	180	180	180	180
	LD	162	165	165	165	165	165	230	230	230	230
	LE	3	6	6	6	6	6	3.2	3.2	3.2	3.2
	LF	12	12	12	12	12	12	18	18	18	18
	LZ	9	9	9	9	9	9	13.5	13.5	13.5	13.5

■ RSMD Motor - Shaft End Dimension

Item	Category	RSMD_			
		10B~20B	25B~30B	35B~40B	45B~50B
	LW	45	55	55	55
	LK	41	51	51	50
	KW	8h9	8h9	8h9	10h9
	KH	7	7	7	8
	RH	18	20	24	30

■ RSMD Motor - Connector Specifications

Item	Category	Motor				Encoder				
		RSMD_		Encoder		전용량				
Part no.		08B ~ 25B	30B ~ 50B	08B ~ 25B	30B ~ 50B	MS3102A 20-29P				
		MS 3102A 20-4P	MS 3102A 22-22P	MS 3102A 20-18P	MS 3102A 24-11P					
Pin spec.		Pin no.	Function	Pin no.	Function	Pin no.	Function (17bit)	Pin no.	Function (2500ppr)	
		A	U	G	A	Brake	G	GND (0V)	A	A
		B	V	H	B	Brake	H	VCC (+5V)	B	/A
		C	W	A	C		J	FG	C	B
		D	FG	F	D	U	K	SD	D	/B
				I	E	V	L	/SD	E	Z
				B	F	W	S	BAT-	F	/Z
				E	G	FG	T	BAT+	G	GND (0V)
				D	H	FG			H	VCC (+5V)
				C	I				J	FG
Outline		MS 3102A 20-4P, 22-22P	MS 3102A 20-18P	MS 3102A 24-11P	MS 3102A 20-29P					

RSMH Motor

Basic Specifications

Item	Category	Unit	RSMH_						
			05B	10B	15B	20B	30B	40B	50B
Flange Size	mm		130	130	130	180	180	180	180
Rated Output	kW		0.5	1	1.5	2	3	4	5
Rated Speed	r/min		2000						
Max. Speed	r/min		3000						
Rated Torque	N·m		2.39	4.77	7.15	9.55	14.32	19.1	23.87
	kgf·cm		24.4	48.6	72.9	97.4	146	195	243
Max. Instantaneous Torque	N·m		6	14.4	21.5	28.5	42.9	56.4	71.4
	kgf·cm		61	147	219.2	291	437	576	729
Rated Current	A(rms)		3.2	5.6	9.4	12.3	17.8	23.4	28
Max. Instantaneous Current	A(rms)		8.13	16.83	28.29	36.70	53.61	70.72	84.87
Rotor Moment of Inertia (Non Brake)	$\times 10^{-4} \text{kg}\cdot\text{m}^2$		14	26	42.9	62	94.1	120	170
	gf·cm·sec ²		14.3	26.5	43.8	63.3	96	122.4	173.5
Rotor Moment of Inertia (Brake)	$\times 10^{-4} \text{kg}\cdot\text{m}^2$		15.2	27.2	44.1	67.9	100	126	176
	gf·cm·sec ²		15.5	27.8	45	69.3	102	128.6	179.6
Electrical Time Constant	ms		17	18	22	26	26	30	31
Mechanical Time Constant (Non Brake)	ms		4.8	3.4	3.5	2.5	2.9	2.6	2.6
Mechanical Time Constant (Brake)	ms		5.2	3.6	3.6	2.7	3.1	2.7	2.7
Power Rate (Non Brake)	kW/s		4.1	8.9	12.2	15	22.2	31.1	34.1
Power Rate (Brake)	kW/s		3.8	8.5	11.8	13.7	20.9	29.6	32.9
Poles	poles		8						
Input Voltage	VAC		220/220						
Insulation Class	-		F						
Vibration	-		V-15						
Allowable Radial Shaft Load	N		490	490	490	784	784	784	784
Allowable Thrust Shaft Load	N		196	196	196	343	343	343	343
Color	-		Black						
Weight	kg		5.3	8.5	10	16	18.2	22	26.7
Weight (Brake)	kg		6.9	9.5	11.6	19.5	21.7	25.5	30.2

[Caution]

1. The above characteristics are typical characteristics when driving a sinusoidal wave. (Mid-value 20°C)
2. The surface temperature of the motor should be below 65°C.
3. Inertia, rated current, Max. instantaneous current, electrical time constant, mechanical time constant, power rate, product weight, etc might be changed in case of using brake type and oil seal type.

RSMH Motor - Torque Speed Curves

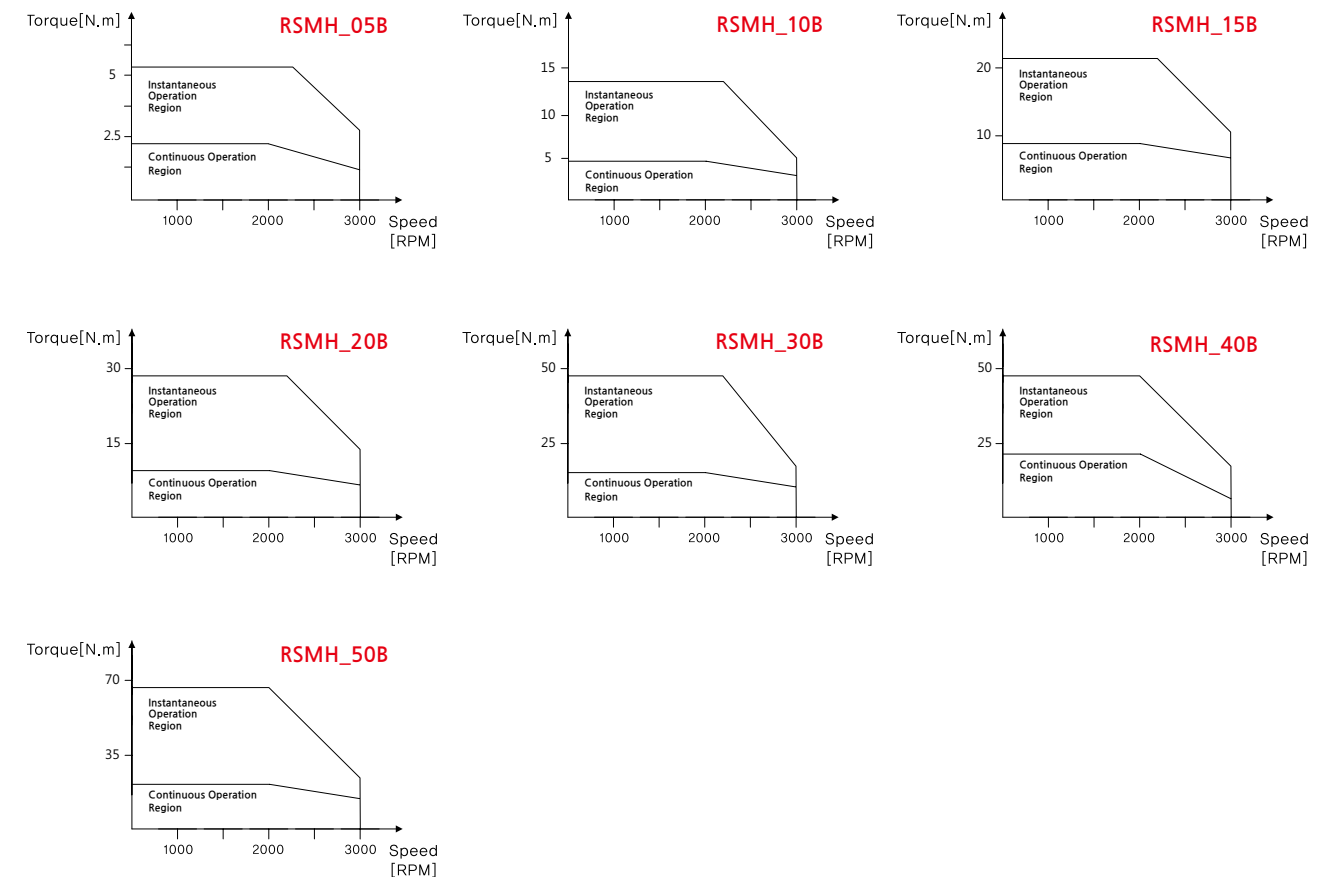

RSMH Motor - Holding Brake Specification

Item	Category	Unit	RSMH_					
			05B	10B	15B	20B	30B	40B
Rated Voltage		VDC	DC 24V ±10%					
Static Friction Torque		N·m	16.5			25		
Rotor Moment of Inertia		$10^{-4} \text{kg}\cdot\text{m}^2$	1.2			4.7		
Brake Absorbing Time		ms	110			160		
Brake Releasing Time		ms	50			75		

■ RSMH Motor - External Dimension Outline

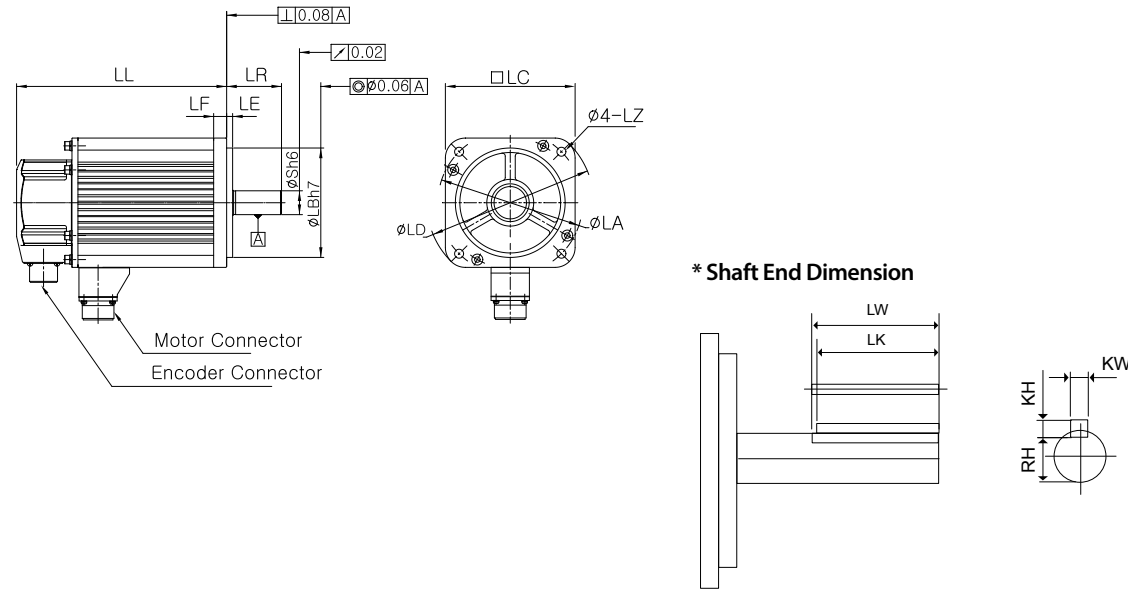

■ RSMH Motor - External Dimension

Item	Category	RSMH_							
		05B	10B	15B	20B	30B	40B	50B	
LL	Non Brake	158	183	208	200	215	230	260	
	Brake	183	208	233	225	240	255	285	
	LR	70	70	70	80	80	80	80	
	S	22	22	22	35	35	35	35	
	LA	145	145	145	200	200	200	200	
	LB	110	110	110	114.3	114.3	114.3	114.3	
	LC	130	130	130	180	180	180	180	
	LD	165	165	165	230	230	230	230	
	LE	6	6	6	3.2	3.2	3.2	3.2	
	LF	12	12	12	18	18	18	18	
	LZ	9	9	9	13.5	13.5	13.5	13.5	

■ RSMH Motor - Shaft End Dimension

Item	Category	RSMH_	
		05B~15B	20B~50B
LW		45	55
LK		41	50
KW		8h9	10h9
KH		7	8
RH		18	30

■ RSMH Motor - Connector Specifications

Item	Category	Motor				Encoder				
		RSMH_				전용량				
Part no.		05B ~ 15B	20B ~ 50B	05B ~ 15B	20B ~ 50B	MS3102A 20-29P				
		MS 3102A 20-4P	MS 3102A 22-22P	MS 3102A 20-18P	MS 3102A 24-11P					
Pin spec.		Pin no.	Function	Pin no.	Function	Pin no.	Function (17bit)	Pin no.	Function (2500ppr)	
		A	U	G	A	Brake	G	GND (0V)	A	A
		B	V	H	B	Brake	H	VCC (+5V)	B	/A
		C	W	A	C		J	FG	C	B
		D	FG	F	D	U	K	SD	D	/B
				I	E	V	L	/SD	E	Z
				B	F	W	S	BAT-	F	/Z
				E	G	FG	T	BAT+	G	GND (0V)
				D	H	FG			H	VCC (+5V)
				C	I				J	FG
Outline		MS 3102A 20-4P, 22-22P		MS 3102A 20-18P		MS 3102A 20-18P		MS 3102A 20-29P		

Cable Specifications

Motor Power Cable - CSMT

Outline

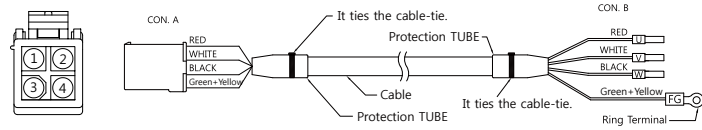

Wiring Specification (Wire Gage : AWG 18)

PIN	Function	Color
1	U phase	3 core cable : Red
2	V phase	3 core cable : White
3	W phase	3 core cable : Black
4	Frame GND	FG Wire (Green+Yellow)

Connector Specification

Remark	Description	Specification	Marker
CON.A	Connector	172159-1	TE
	Terminal	170362-1	
CON.B	RING Terminal	GP-140078	KET or Equivalent product
	Ferrule Terminal	CE010012	Dong-A Bestech

Motor Power Cable - CSMA

Outline

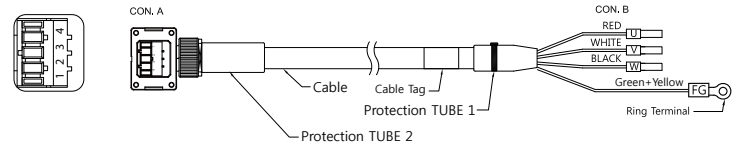

Wiring Specification (Wire Gage : AWG 18)

PIN	Function	Color
1	Frame GND	FG Wire (Green+Yellow)
2	U Phase	3 core cable : Red
3	V Phase	3 core cable : White
4	W Phase	3 core cable : Black

Connector Specification

Remark	Description	Specification	Marker
CON.A	Connector	JN6F504SJ2	JAE
	Terminal	ST-JN5-S-C1B-2500	
CON.B	RING Terminal	GP-140078	KET or Equivalent product
	Ferrule Terminal	CE010012	Dong-A Bestech

Motor Power Cable - CSMS, CSMD, CSMH

1.5kW or less

- CSMS, CSMD and CSMH Motor
- Apply on 1.5kW or less of CSD7 drive

- Wire Gage : Power (AWG 14), Brake (AWG 20)
- CSMH motor brake cable is provided separately from 1kW.

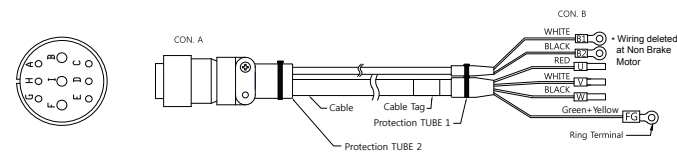

2.5kW or less

- CSMS, CSMD Motor (2kW ~ 2.5kW)
- Wire Gage : Power (AWG 12), Brake (AWG 20)

- Apply on 2.5kW or higher of CSD7 drive
- CSMH motor brake cable is provided separately from 1kW.

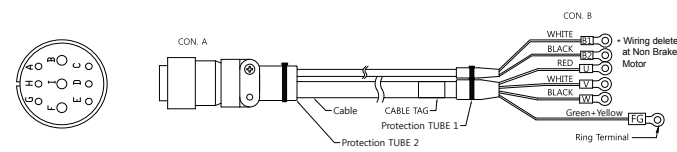

Wiring Specification

PIN	Function	Color	PIN	Function	Color
A	-	-	F	U phase	3 core cable : Red
B	W phase	3 core cable : Black	G	Brake (B1)	2 core cable : White, Brake Motor Only
C/D	-	-	H	Brake (B2)	2 core cable : Black, Brake Motor Only
E	Frame GND	FG Wire (Green+Yellow)	I	V phase	3 core cable : White

Connector Specification

Remark	Description	Specification	Marker	
CON.A	MS Connector	MS3106A20-18S, RoHS	Military Standard Compliance product	
CON.B	1.5kW or less	RING Terminal (B1, B2)	GP-140078	KET or Equivalent product
		Ferrule Terminal	CE025012	Dong-A Bestech
	CSMS, CSMD 2kW ~ 2.5kW	RING Terminal (B1, B2)	GP-140078	KET or Equivalent product
		RING Terminal (U, V, W, FG)	4SQ-Ø4	UL Approved product

3kW or more

- CSMS, CSMD Motor (Applied to 3kW ~ 5kW)
- Wire Gage :
 - Power : AWG 12 (3.5kW or less), AWG 10 (5kW or less)
 - Brake : AWG 20

2kW or more

- CSMH Motor (Applied to 2kW ~ 5kW)
- Wire Gage :
 - Power : AWG 12 (3.5kW or less), AWG 10 (5kW or less)
 - CSMH motor brake cable is provided separately from 1kW.

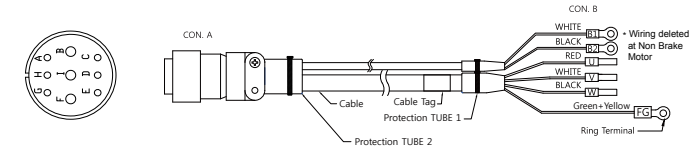

Wiring Specification

PIN	Function	Color	PIN	Function	Color
A	Brake (B1)	2 core cable : White, Brake Motor Only	E	V Phase	3 core cable : White
B	Brake (B2)	2 core cable : Black, Brake Motor Only	F	W Phase	3 core cable : Black
C	-	-	G	Frame GND	FG Wire (Green+Yellow)
D	U Phase	3 core cable : Red	H/I	-	-

Connector Specification

Remark	Description	Specification	Marker	
CON.A	MS Connector	MS3106A24-11S, RoHS	Military Standard Compliance product	
CON.B	3.5kW or less (CSMH Motor : 2kW ~ 3kW)	RING Terminal (B1, B2)	GP-140078	KET or Equivalent product
		RING Terminal (U, V, W, FG)	4SQ-Ø4	UL Approved product
	4kW ~ 5kW	RING Terminal (B1, B2)	GP-140078	KET or Equivalent product
		RING Terminal (U, V, W, FG)	5.5SQ-Ø4	UL Approved product

Motor Power Cable - RSMZ, RSMS, RSMD, RSMH

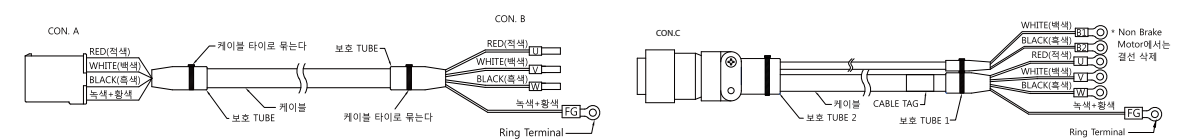

Wiring, Connector Specification

	CON.A	CON.C	CON.C	CON.C
	MS3102A 20-4P	MS3102A 22-22P	MS3102A 20-18P	MS3102A 24-11P
PIN	Function	Function	Function	Function
A	U Phase	U Phase	-	Brake
B	V Phase	V Phase	W Phase	Brake
C	W Phase	W Phase	-	-
D	Frame GND	Frame GND	-	U Phase
E	-	-	Frame GND	V Phase
F	-	-	U Phase	W Phase
G	-	-	Brake	Frame GND
H	-	-	Brake	-
I	-	-	V Phase	-

■ Motor Encoder Cable - CSMT, RSMZ

• Outline

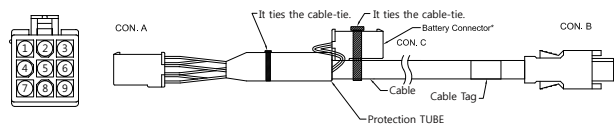

• Connector Specification

Remark	Description	Specification	Marker
CON.A	Connector	172161-1	TE
	Terminal	170361-1	
CON.B	Plug	3E206-0100KV	3M
	Cover	3E306-3200-008	
CON.C	Connector	DF1B-2ES-2.5RC	HRS
	Terminal	DF1B-2428SCF	

• Wiring Specification (Wire Gauge: AWG 24)

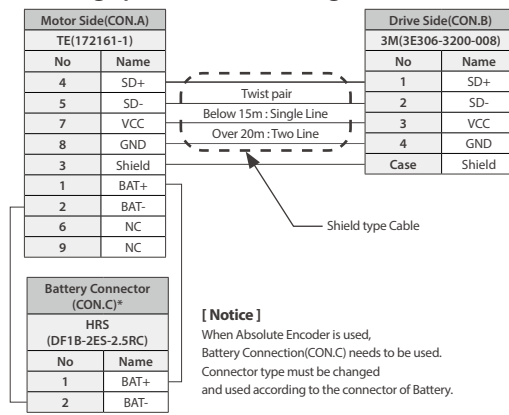

■ Motor Encoder Cable - RSMS, RSMD, RSMH

• Outline

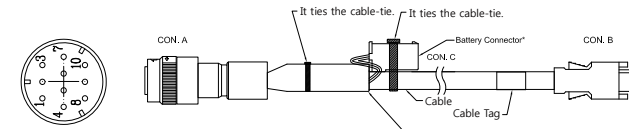

• Wiring Specification (Wire Gauge : AWG 24)

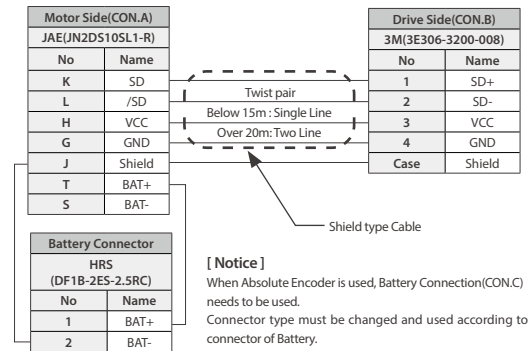

■ Linear Motor Encoder Cable - RENISHAW, HEIDENHAIN

• Outline

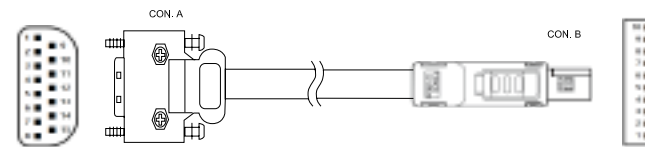

• Wiring Specification

Remark	Description	Specification	Marker
CON.A	Connector	17JE-13150-02-D1-A	DDK
CON.B	Plug	MUF-PK10K-X	JST

■ Motor Encoder Cable - CSMA

• Outline

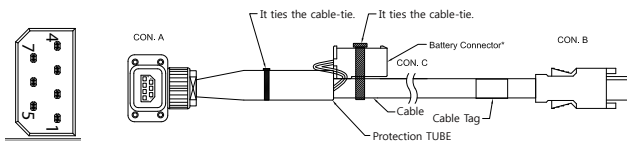

• Connector Specification

Remark	Description	Specification	Marker
CON.A	Connector	JN6FR07SM1	JAE
	Terminal	LY10-C2-A1-10000	
CON.B	Plug	3E206-0100KV	3M
	Cover	3E306-3200-008	
CON.C	Connector	DF1B-2ES-2.5RC	HRS
	Terminal	DF1B-2428SCF	

• Wiring Specification (Wire Gauge: AWG 24)

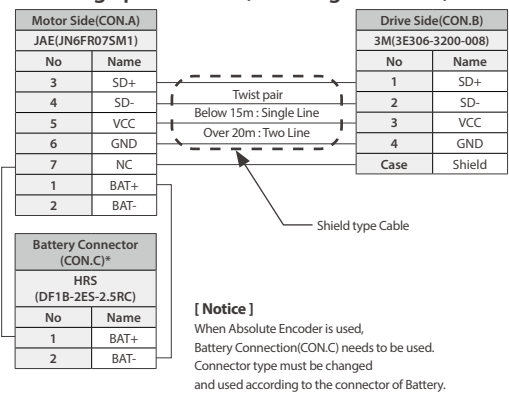

• Wiring Specification (Wire Gauge: AWG 24) - RENISHAW

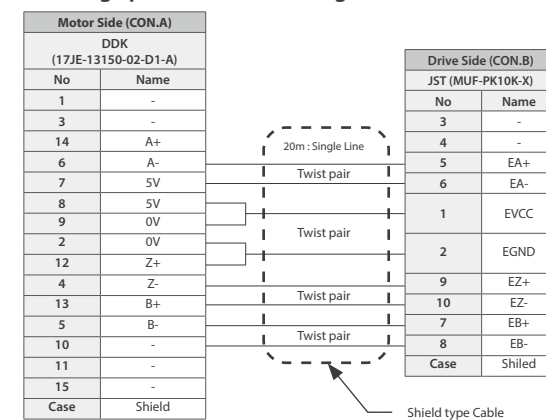

• Wiring Specification (Wire Gauge: AWG 24) - HEIDENHAIN

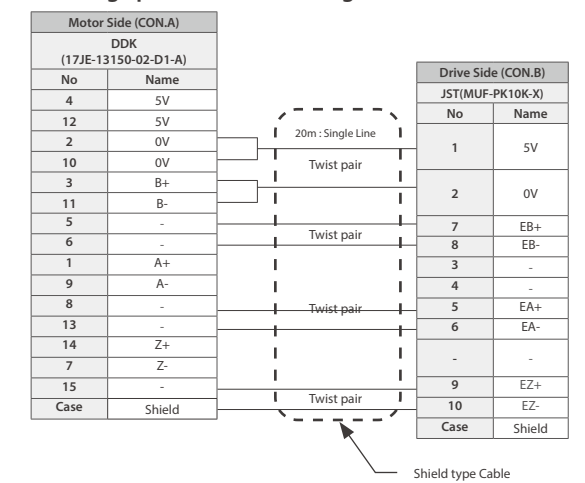

■ Motor Encoder Cable - CSMS, CSMD, CSMH

• Outline

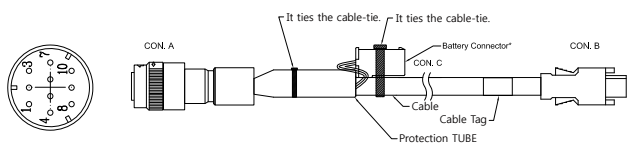

• Connector Specification

Remark	Description	Specification	Marker
CON.A	Connector	JN2DS10SL1-R	JAE
	Terminal	JN1-22-22S	
CON.B	Plug	3E206-0100KV	3M
	Cover	3E306-3200-008	
CON.C	Connector	DF1B-2ES-2.5RC	HRS
	Terminal	DF1B-2428SCF	

• Wiring Specification (Wire Gauge: AWG 24)

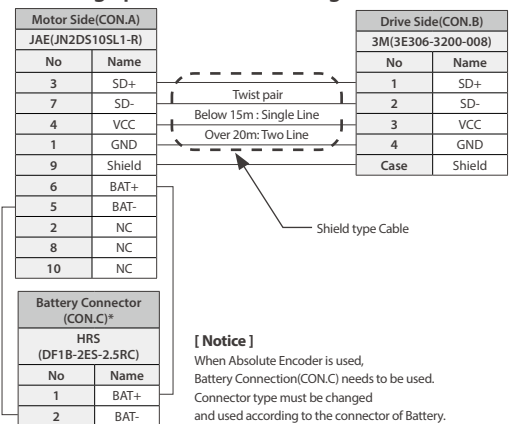

• Outline (Hall Signal Cable)

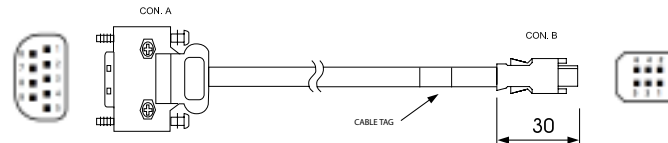

• Wiring Specification

Remark	Description	Specification	Maker
CON.A	Connector	17JE-13090-02-D1	DDK
CON.B	Plug	3E206	Molex
	Cover	3E306	Molex

• Wiring Specification (Wire Gauge: AWG 24)

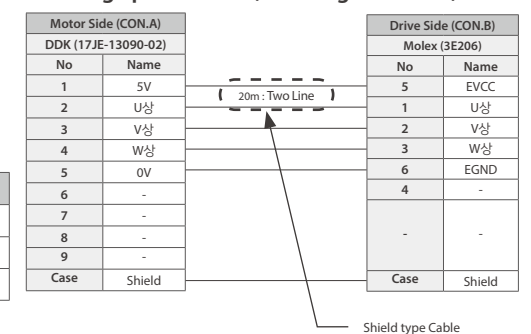

■ Motor Brake Cable - CSMT, RSMZ

• Outline

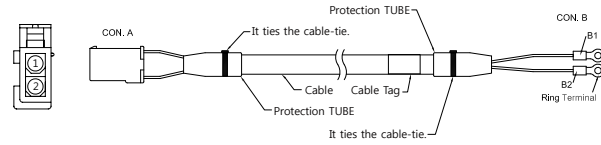

• Connector Specification

Remark	Description	Specification	Marker
CON.A	Connector	172233-1	TE
	Terminal	170362-1	
CON.B	RING Terminal	GP-140078	KET or Equivalent product

• Wiring Specification (Wire Gage : AWG 20)

PIN	Function	Color
1	B1	2 core cable : White
2	B2	2 core cable : Black

■ Motor Brake Cable - CSMA

• Outline

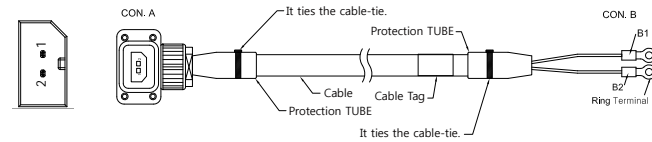

• Connector Specification

Remark	Description	Specification	Marker
CON.A	Connector	JN6FR02SM1	JAE
	Terminal	LY10-C2-A1-10000	
CON.B	RING Terminal	GP-140078	KET or Equivalent product

• Wiring Specification (Wire Gage : AWG 20)

PIN	Function	Color
1	B1	2 core cable : White
2	B2	2 core cable : Black

■ Motor Brake Cable - CSMH

• Outline

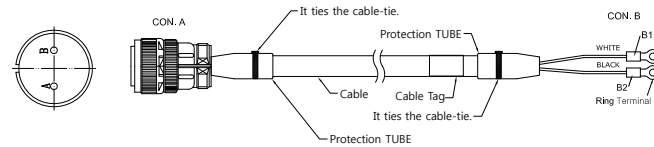

• Connector Specification

Remark	Description	Specification	Marker
CON.A	Connector	MS3106B10SL-4S	Military Standard Compliance product
CON.B	RING Terminal	GP-140078	KET or Equivalent product

• Wiring Specification (Wire Gage : AWG 20)

PIN	Function	Color
A	B1	2 core cable : White
B	B2	2 core cable : Black

* It is motor brake cable provided seperately from 1kW motor.

■ RS485 Cable - 1) Drive To Drive

• Outline

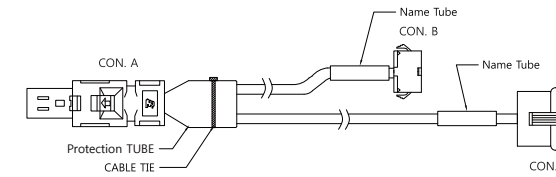

• Connector Specification

Remark	Description	Specification	Marker
CON.A	Industry mini I/O Kit	2040008-1	TE
CON.B	Connector	SMP-05V-NC	JST
	Terminal	SHF-001T-0.8B5	
CON.C	Connector	SMR-05V-N	JST
	Terminal	SYM-001T-P0.6	

• Wiring Specification

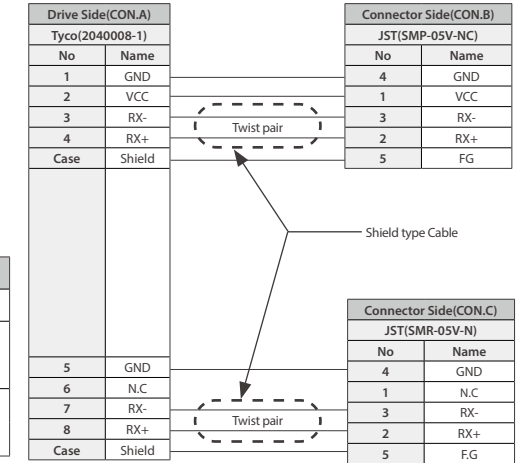

■ RS485 Cable - 2) Drive To Controller

• Outline

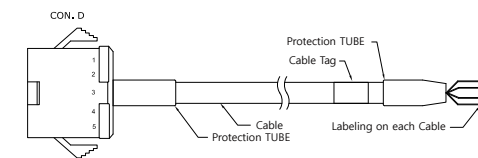

• Connector Specification

Remark	Description	Specification	Marker
CON.D	Connector	SMP-05V-NC	JST
	Terminal	SHF-001T-0.8B5	

• Wiring Specification

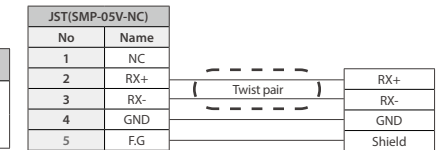

■ RS485 Termination Connector

• Outline

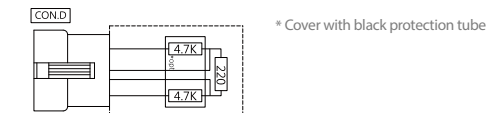

• Connector Specification

Remark	Description	Specification	Marker
CON.D	Connector	SMR-05V-N	JST
	Terminal	SYM-001T-P0.6	

• Wiring Specification

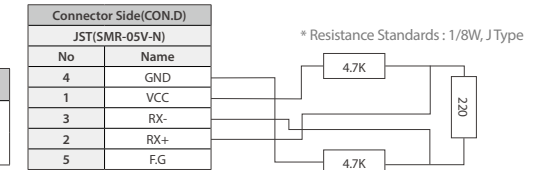

I/O Cable - Pulse/Analog Model

• Outline

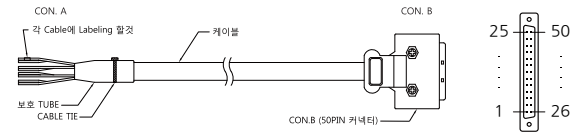

• Connector Specification

Remark	Description	Specification	Marker
CON.B	Plug	10150-3000 VE	3M
	Cover	10350-52F0-008(LATCH)	3M

• Wiring Specification

Connector Side(CON.B)					
10150-3000 VE					
No	Name	No	Name	No	Name
1	+24V IN	18	Z-PULSE-	35	PS+
2	+24V IN	19	VCMD+	36	PS-
3	INPUT1	20	VCMD-	37	FAULT1 / OUTPUT4
4	INPUT2	21	ICMD+	38	FAULT2 / OUTPUT5
5	INPUT3	22	ICMD-	39	FAULT3 / OUTPUT6
6	INPUT4	23	HF-SIGN+	40	FCOM/OUTCOM
7	INPUT5	24	HF-SIGN-	41	OUTPUT1+
8	INPUT6	25	24V-SIGN+	42	OUTPUT1-
9	INPUT7	26	INPUT8	43	OUTPUT2+
10	E-STOP	27	HS-INPUT1(REG1) / INPUT9	44	OUTPUT2-
11	PLUS+	28	HS-INPUT(REG2) / INPUT10	45	/FAULT+
12	PLUS-	29	EA+	46	/FAULT-
13	SIGN+	30	EA-	47	OUTPUT3+
14	SIGN-	31	EB+	48	OUTPUT3-
15	HF-PLUS+	32	EB-	49	24V-PLUS+
16	HF-PLUS-	33	EC+	50	HS-INPUT COM
17	Z-PULSE+	34	EC-		

I/O Cable - Network Model

• Outline

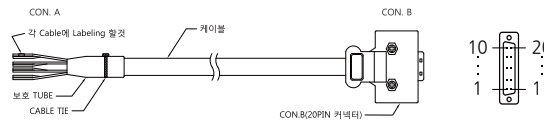

• Connector Specification

Remark	Description	Specification	Marker
CON.B	Plug	10120-3000 VE	3M
	Cover	10320-52F0-008(LATCH)	3M

• Wiring Specification

Connector Side(CON.B)			
10120-3000 VE			
No	Name	No	Name
1	COM_24V	11	EA+
2	TP_24V	12	EA-
3	Touch Probe1	13	EB+
4	Touch Probe2	14	EB-
5	INPUT1	15	OUTPUT1+
6	INPUT2	16	OUTPUT1-
7	INPUT3	17	OUTPUT2+
8	INPUT4	18	OUTPUT2-
9	E-STOP	19	OUTPUT3+
10	Signal GND	20	OUTPUT3-

EtherCAT Cable

• Outline



• Connector Specification

Remark	Description	Specification	Marker
CON.A/B	Plug	5-569530-2	AMP
Cable	-	S05E004	LS

• Wiring Specification (Wire Gage)

No	Description	No	Color	Signal	Remark
1	-----	1	ORG / WHT	Tx+	Pair
2	-----	2	ORG	Tx-	
5	-----	5	BLU / WHT	NC	Pair
4	-----	4	BLU	NC	
3	-----	3	GRN / WHT	Rx+	Pair
6	-----	6	GRN	Rx-	
7	-----	7	BRN / WHT	NC	Pair
8	-----	8	BRN	NC	
Frame	Shield	Frame	-	-	-

[Notice]

- Cable : At least higher than Category 5(CAT.5), (EN50173 or ISO/IEC 11801).
- Connector : RJ45 Type, Pin Map should be correspondingly wiring on EtherCAT Standard(ISO/IEC8802-3).
- Distance between EtherCAT products should be maximum 100m.
- Use of Shield Twisted Pair(STP) Cable and Shield RJ45 Type Connector.

Model Information

※ Product specifications and model names are subject to change without prior notice to improve product performance.

CSD7 Servo Drive Information

• Pulse/Analog

Rated Output	Model name	Description
100W	CSD7_01BX1	Basic, 100W, 220VAC, 50/60Hz
	CSD7_01BX1_L	Basic, 100W, 220VAC, 50/60Hz, Linear
	CSD7_01BXF1	Advanced, 100W, 220VAC, 50/60Hz
	CSD7_01BXF1_L	Advanced, 100W, 220VAC, 50/60Hz, Linear
200W	CSD7_02BX1	Basic, 200W, 220VAC, 50/60Hz
	CSD7_02BX1_L	Basic, 200W, 220VAC, 50/60Hz, Linear
	CSD7_02BXF1	Advanced, 200W, 220VAC, 50/60Hz
	CSD7_02BXF1_L	Advanced, 200W, 220VAC, 50/60Hz, Linear
400W	CSD7_04BX1	Basic, 400W, 220VAC, 50/60Hz
	CSD7_04BX1_L	Basic, 400W, 220VAC, 50/60Hz, Linear
	CSD7_04BXF1	Advanced, 400W, 220VAC, 50/60Hz
	CSD7_04BXF1_L	Advanced, 400W, 220VAC, 50/60Hz, Linear
800W	CSD7_08BX1	Basic, 800W, 220VAC, 50/60Hz
	CSD7_08BX1_L	Basic, 800W, 220VAC, 50/60Hz, Linear
	CSD7_08BXF1	Advanced, 800W, 220VAC, 50/60Hz
	CSD7_08BXF1_L	Advanced, 800W, 220VAC, 50/60Hz, Linear
1kW	CSD7_10BX1	Basic, 1kW, 220VAC, 50/60Hz
	CSD7_10BX1_L	Basic, 1kW, 220VAC, 50/60Hz, Linear
	CSD7_10BXF1	Advanced, 1kW, 220VAC, 50/60Hz
	CSD7_10BXF1_L	Advanced, 1kW, 220VAC, 50/60Hz, Linear
1.5kW	CSD7_15BX1	Basic, 1.5kW, 220VAC, 50/60Hz
	CSD7_15BX1_L	Basic, 1.5kW, 220VAC, 50/60Hz, Linear
	CSD7_15BXF1	Advanced, 1.5kW, 220VAC, 50/60Hz
	CSD7_15BXF1_L	Advanced, 1.5kW, 220VAC, 50/60Hz, Linear
2.5kW	CSD7_25BXF1	Advanced, 2.5kW, 220VAC, 50/60Hz
3.5kW	CSD7_35BXF1	Advanced, 3.5kW, 220VAC, 50/60Hz
5kW	CSD7_50BXF1	Advanced, 5kW, 220VAC, 50/60Hz

• Network

Rated Output	Model name	Description
100W	CSD7_01BN1	Basic, 100W, 220VAC, 50/60Hz
	CSD7_01BN1_L	Basic, 100W, 220VAC, 50/60Hz, Linear
	CSD7_01BNF1	Advanced, 100W, 220VAC, 50/60Hz
	CSD7_01BNF1_L	Advanced, 100W, 220VAC, 50/60Hz, Linear
200W	CSD7_02BN1	Basic, 200W, 220VAC, 50/60Hz
	CSD7_02BN1_L	Basic, 200W, 220VAC, 50/60Hz, Linear
	CSD7_02BNF1	Advanced, 200W, 220VAC, 50/60Hz
	CSD7_02BNF1_L	Advanced, 200W, 220VAC, 50/60Hz, Linear
400W	CSD7_04BN1	Basic, 400W, 220VAC, 50/60Hz
	CSD7_04BN1_L	Basic, 400W, 220VAC, 50/60Hz, Linear
	CSD7_04BNF1	Advanced, 400W, 220VAC, 50/60Hz
	CSD7_04BNF1_L	Advanced, 400W, 220VAC, 50/60Hz, Linear
800W	CSD7_08BN1	Basic, 800W, 220VAC, 50/60Hz
	CSD7_08BN1_L	Basic, 800W, 220VAC, 50/60Hz, Linear
	CSD7_08BNF1	Advanced, 800W, 220VAC, 50/60Hz
	CSD7_08BNF1_L	Advanced, 800W, 220VAC, 50/60Hz, Linear
1kW	CSD7_10BN1	Basic, 1kW, 220VAC, 50/60Hz
	CSD7_10BN1_L	Basic, 1kW, 220VAC, 50/60Hz, Linear
	CSD7_10BNF1	Advanced, 1kW, 220VAC, 50/60Hz
	CSD7_10BNF1_L	Advanced, 1kW, 220VAC, 50/60Hz, Linear
1.5kW	CSD7_15BN1	Basic, 1.5kW, 220VAC, 50/60Hz
	CSD7_15BN1_L	Basic, 1.5kW, 220VAC, 50/60Hz, Linear
	CSD7_15BNF1	Advanced, 1.5kW, 220VAC, 50/60Hz
	CSD7_15BNF1_L	Advanced, 1.5kW, 220VAC, 50/60Hz, Linear
2.5kW	CSD7_25BNF1	Advanced, 2.5kW, 220VAC, 50/60Hz
3.5kW	CSD7_35BNF1	Advanced, 3.5kW, 220VAC, 50/60Hz
5kW	CSD7_50BNF1	Advanced, 5kW, 220VAC, 50/60Hz

■ CSD7 Servo Motor Information

• CSMT Series

Rated Output	Model name	Description
50W	CSMT_A5BQ1ABT3	50W, 17bit Absolute, Brake, Key
	CSMT_A5BQ1ANT3	50W, 17bit Absolute, Standard, Key
	CSMT_A5BQ1AST3	50W, 17bit Absolute, Standard, Key, Oil-Seal
	CSMT_A5BQ1ATT3	50W, 17bit Absolute, Brake, Key, Oil-Seal
	CSMT_A5BR1ABT3	50W, 17bit Incremental, Brake, Key
	CSMT_A5BR1ANT3	50W, 17bit Incremental, Standard, Key
	CSMT_A5BR1AST3	50W, 17bit Incremental, Standard, Key, Oil-Seal
	CSMT_A5BR1ATT3	50W, 17bit Incremental, Brake, Key, Oil-Seal
100W	CSMT_01BQ1ABT3	100W, 17bit Absolute, Brake, Key
	CSMT_01BQ1ANT3	100W, 17bit Absolute, Standard, Key
	CSMT_01BQ1AST3	100W, 17bit Absolute, Standard, Key, Oil-Seal
	CSMT_01BQ1ATT3	100W, 17bit Absolute, Brake, Key, Oil-Seal
	CSMT_01BR1ABT3	100W, 17bit Incremental, Brake, Key
	CSMT_01BR1ANT3	100W, 17bit Incremental, Standard, Key
	CSMT_01BR1AST3	100W, 17bit Incremental, Standard, Key, Oil-Seal
	CSMT_01BR1ATT3	100W, 17bit Incremental, Brake, Key, Oil-Seal
200W	CSMT_02BQ1ABT3	200W, 17bit Absolute, Brake, Key
	CSMT_02BQ1ANT3	200W, 17bit Absolute, Standard, Key
	CSMT_02BQ1AST3	200W, 17bit Absolute, Standard, Key, Oil-Seal
	CSMT_02BQ1ATT3	200W, 17bit Absolute, Brake, Key, Oil-Seal
	CSMT_02BR1ABT3	200W, 17bit Incremental, Brake, Key
	CSMT_02BR1ANT3	200W, 17bit Incremental, Standard, Key
	CSMT_02BR1AST3	200W, 17bit Incremental, Standard, Key, Oil-Seal
	CSMT_02BR1ATT3	200W, 17bit Incremental, Brake, Key, Oil-Seal
400W	CSMT_04BQ1ABT3	400W, 17bit Absolute, Brake, Key
	CSMT_04BQ1ANT3	400W, 17bit Absolute, Standard, Key
	CSMT_04BQ1AST3	400W, 17bit Absolute, Standard, Key, Oil-Seal
	CSMT_04BQ1ATT3	400W, 17bit Absolute, Brake, Key, Oil-Seal
	CSMT_04BR1ABT3	400W, 17bit Incremental, Brake, Key
	CSMT_04BR1ANT3	400W, 17bit Incremental, Standard, Key
	CSMT_04BR1AST3	400W, 17bit Incremental, Standard, Key, Oil-Seal
	CSMT_04BR1ATT3	400W, 17bit Incremental, Brake, Key, Oil-Seal
600W	CSMT_06BQ1ABT3	600W, 17bit Absolute, Brake, Key
	CSMT_06BQ1ANT3	600W, 17bit Absolute, Standard, Key
	CSMT_06BQ1AST3	600W, 17bit Absolute, Standard, Key, Oil-Seal
	CSMT_06BQ1ATT3	600W, 17bit Absolute, Brake, Key, Oil-Seal
	CSMT_06BR1ABT3	600W, 17bit Incremental, Brake, Key
	CSMT_06BR1ANT3	600W, 17bit Incremental, Standard, Key
	CSMT_06BR1AST3	600W, 17bit Incremental, Standard, Key, Oil-Seal
	CSMT_06BR1ATT3	600W, 17bit Incremental, Brake, Key, Oil-Seal
750W	CSMT_08BQ1ABT3	750W, 17bit Absolute, Brake, Key
	CSMT_08BQ1ANT3	750W, 17bit Absolute, Standard, Key
	CSMT_08BQ1AST3	750W, 17bit Absolute, Standard, Key, Oil-Seal
	CSMT_08BQ1ATT3	750W, 17bit Absolute, Brake, Key, Oil-Seal
	CSMT_08BR1ABT3	750W, 17bit Incremental, Brake, Key
	CSMT_08BR1ANT3	750W, 17bit Incremental, Standard, Key
	CSMT_08BR1AST3	750W, 17bit Incremental, Standard, Key, Oil-Seal
	CSMT_08BR1ATT3	750W, 17bit Incremental, Brake, Key, Oil-Seal
950W	CSMT_10BQ1ABT3	950W, 17bit Absolute, Brake, Key
	CSMT_10BQ1ANT3	950W, 17bit Absolute, Standard, Key
	CSMT_10BQ1AST3	950W, 17bit Absolute, Standard, Key, Oil-Seal
	CSMT_10BQ1ATT3	950W, 17bit Absolute, Brake, Key, Oil-Seal
	CSMT_10BR1ABT3	950W, 17bit Incremental, Brake, Key
	CSMT_10BR1ANT3	950W, 17bit Incremental, Standard, Key
	CSMT_10BR1AST3	950W, 17bit Incremental, Standard, Key, Oil-Seal
	CSMT_10BR1ATT3	950W, 17bit Incremental, Brake, Key, Oil-Seal

• CSMA Series

Rated Output	Model name	Description
50W	CSMA_A5BT1ABT3	50W, 23bit Incremental/Absolute, Brake, Key
	CSMA_A5BT1ANT3	50W, 23bit Incremental/Absolute, Standard, Key
	CSMA_A5BT1AST3	50W, 23bit Incremental/Absolute, Standard, Key, Oil-Seal
	CSMA_A5BT1ATT3	50W, 23bit Incremental/Absolute, Brake, Key, Oil-Seal
100W	CSMA_01BT1ABT3	100W, 23bit Incremental/Absolute, Brake, Key
	CSMA_01BT1ANT3	100W, 23bit Incremental/Absolute, Standard, Key
	CSMA_01BT1AST3	100W, 23bit Incremental/Absolute, Standard, Key, Oil-Seal
200W	CSMA_02BT1ABT3	200W, 23bit Incremental/Absolute, Brake, Key
	CSMA_02BT1ANT3	200W, 23bit Incremental/Absolute, Standard, Key
	CSMA_02BT1AST3	200W, 23bit Incremental/Absolute, Standard, Key, Oil-Seal
400W	CSMA_04BT1ABT3	400W, 23bit Incremental/Absolute, Brake, Key
	CSMA_04BT1ANT3	400W, 23bit Incremental/Absolute, Standard, Key
	CSMA_04BT1AST3	400W, 23bit Incremental/Absolute, Standard, Key, Oil-Seal
	CSMA_04BT1ATT3	400W, 23bit Incremental/Absolute, Brake, Key, Oil-Seal
600W	CSMA_06BT1ABT3	600W, 23bit Incremental/Absolute, Brake, Key
	CSMA_06BT1ANT3	600W, 23bit Incremental/Absolute, Standard, Key
	CSMA_06BT1AST3	600W, 23bit Incremental/Absolute, Standard, Key, Oil-Seal
750W	CSMA_08BT1ABT3	750W, 23bit Incremental/Absolute, Brake, Key
	CSMA_08BT1ANT3	750W, 23bit Incremental/Absolute, Standard, Key
	CSMA_08BT1AST3	750W, 23bit Incremental/Absolute, Standard, Key, Oil-Seal
	CSMA_08BT1ATT3	750W, 23bit Incremental/Absolute, Brake, Key, Oil-Seal

• CSMS Series

Rated Output	Model name	Description
1kW	CSMS_10BT3AST3	1kW, 23bit Absolute, Standard, Key, Oil-Seal
	CSMS_10BT3ATT3	1kW, 23bit Absolute, Brake, Key, Oil-Seal
1.5kW	CSMS_15BT3AST3	1.5kW, 23bit Absolute, Standard, Key, Oil-Seal
	CSMS_15BT3ATT3	1.5kW, 23bit Absolute, Brake, Key, Oil-Seal
2kW	CSMS_20BT3AST3	2kW, 23bit Absolute, Standard, Key, Oil-Seal
	CSMS_20BT3ATT3	2kW, 23bit Absolute, Brake, Key, Oil-Seal
2.5kW	CSMS_25BT3AST3	2.5kW, 23bit Absolute, Standard, Key, Oil-Seal
	CSMS_25BT3ATT3	2.5kW, 23bit Absolute, Brake, Key, Oil-Seal
3kW	CSMS_30BT3AST3	3kW, 23bit Absolute, Standard, Key, Oil-Seal
	CSMS_30BT3ATT3	3kW, 23bit Absolute, Brake, Key, Oil-Seal
3.5kW	CSMS_35BT3AST3	3.5kW, 23bit Absolute, Standard, Key, Oil-Seal
	CSMS_35BT3ATT3	3.5kW, 23bit Absolute, Brake, Key, Oil-Seal
4kW	CSMS_40BT3AST3	4kW, 23bit Absolute, Standard, Key, Oil-Seal
	CSMS_40BT3ATT3	4kW, 23bit Absolute, Brake, Key, Oil-Seal
5kW	CSMS_50BT3AST3	5kW, 23bit Absolute, Standard, Key, Oil-Seal
	CSMS_50BT3ATT3	5kW, 23bit Absolute, Brake, Key, Oil-Seal

• CSMD Series

Rated Output	Model name	Description
750W	CSMD_08BT3AST3	750W, 23bit Absolute, Standard, Key, Oil-Seal
	CSMD_08BT3ATT3	750W, 23bit Absolute, Brake, Key, Oil-Seal
1kW	CSMD_10BT3AST3	1kW, 23bit Absolute, Standard, Key, Oil-Seal
	CSMD_10BT3ATT3	1kW, 23bit Absolute, Brake, Key, Oil-Seal
1.5kW	CSMD_15BT3AST3	1.5kW, 23bit Absolute, Standard, Key, Oil-Seal
	CSMD_15BT3ATT3	1.5kW, 23bit Absolute, Brake, Key, Oil-Seal
2kW	CSMD_20BT3AST3	2kW, 23bit Absolute, Standard, Key, Oil-Seal
	CSMD_20BT3ATT3	2kW, 23bit Absolute, Brake, Key, Oil-Seal
2.5kW	CSMD_25BT3AST3	2.5kW, 23bit Absolute, Standard, Key, Oil-Seal
	CSMD_25BT3ATT3	2.5kW, 23bit Absolute, Brake, Key, Oil-Seal
3kW	CSMD_30BT3AST3	3kW, 23bit Absolute, Standard, Key, Oil-Seal
	CSMD_30BT3ATT3	3kW, 23bit Absolute, Brake, Key, Oil-Seal
3.5kW	CSMD_35BT3AST3	3.5kW, 23bit Absolute, Standard, Key, Oil-Seal
	CSMD_35BT3ATT3	3.5kW, 23bit Absolute, Brake, Key, Oil-Seal
4kW	CSMD_40BT3AST3	4kW, 23bit Absolute, Standard, Key, Oil-Seal
	CSMD_40BT3ATT3	4kW, 23bit Absolute, Brake, Key, Oil-Seal
5kW	CSMD_50BT3AST3	5kW, 23bit Absolute, Standard, Key, Oil-Seal
	CSMD_50BT3ATT3	5kW, 23bit Absolute, Brake, Key, Oil-Seal

3.5kW	RSM_D_35BQ1ASK3	3.5kW, 17bit Absolute, Standard, Key, Oil-Seal
	RSM_D_35BQ1ATK3	3.5kW, 17bit Absolute, Brake, Key, Oil-Seal
	RSM_D_35BR1ASK3	3.5kW, 17bit Incremental, Standard, Key, Oil-Seal
	RSM_D_35BR1ATK3	3.5kW, 17bit Incremental, Brake, Key, Oil-Seal
4kW	RSM_D_40BQ1ASK3	4kW, 17bit Absolute, Standard, Key, Oil-Seal
	RSM_D_40BQ1ATK3	4kW, 17bit Absolute, Brake, Key, Oil-Seal
	RSM_D_40BR1ASK3	4kW, 17bit Incremental, Standard, Key, Oil-Seal
4.5kW	RSM_D_45BQ1ASK3	4.5kW, 17bit Absolute, Standard, Key, Oil-Seal
	RSM_D_45BQ1ATK3	4.5kW, 17bit Absolute, Brake, Key, Oil-Seal
	RSM_D_45BR1ASK3	4.5kW, 17bit Incremental, Standard, Key, Oil-Seal
	RSM_D_45BR1ATK3	4.5kW, 17bit Incremental, Brake, Key, Oil-Seal
5kW	RSM_D_50BQ1ASK3	5kW, 17bit Absolute, Standard, Key, Oil-Seal
	RSM_D_50BQ1ATK3	5kW, 17bit Absolute, Brake, Key, Oil-Seal
	RSM_D_50BR1ASK3	5kW, 17bit Incremental, Standard, Key, Oil-Seal
	RSM_D_50BR1ATK3	5kW, 17bit Incremental, Brake, Key, Oil-Seal

• RSMH Series

Rated Output	Model name	Description
500W	RSMH_05BQ1ASK3	500W, 17bit Absolute, Standard, Key, Oil-Seal
	RSMH_05BQ1ATK3	500W, 17bit Absolute, Brake, Key, Oil-Seal
	RSMH_05BR1ASK3	500W, 17bit Incremental, Standard, Key, Oil-Seal
	RSMH_05BR1ATK3	500W, 17bit Incremental, Brake, Key, Oil-Seal
1kW	RSMH_10BQ1ASK3	1kW, 17bit Absolute, Standard, Key, Oil-Seal
	RSMH_10BQ1ATK3	1kW, 17bit Absolute, Brake, Key, Oil-Seal
	RSMH_10BR1ASK3	1kW, 17bit Incremental, Standard, Key, Oil-Seal
	RSMH_10BR1ATK3	1kW, 17bit Incremental, Brake, Key, Oil-Seal
1.5kW	RSMH_15BQ1ASK3	1.5kW, 17bit Absolute, Standard, Key, Oil-Seal
	RSMH_15BQ1ATK3	1.5kW, 17bit Absolute, Brake, Key, Oil-Seal
	RSMH_15BR1ASK3	1.5kW, 17bit Incremental, Standard, Key, Oil-Seal
	RSMH_15BR1ATK3	1.5kW, 17bit Incremental, Brake, Key, Oil-Seal
2kW	RSMH_20BQ1ASK3	2kW, 17bit Absolute, Standard, Key, Oil-Seal
	RSMH_20BQ1ATK3	2kW, 17bit Absolute, Brake, Key, Oil-Seal
	RSMH_20BR1ASK3	2kW, 17bit Incremental, Standard, Key, Oil-Seal
	RSMH_20BR1ATK3	2kW, 17bit Incremental, Brake, Key, Oil-Seal
3kW	RSMH_30BQ1ASK3	3kW, 17bit Absolute, Standard, Key, Oil-Seal
	RSMH_30BQ1ATK3	3kW, 17bit Absolute, Brake, Key, Oil-Seal
	RSMH_30BR1ASK3	3kW, 17bit Incremental, Standard, Key, Oil-Seal
	RSMH_30BR1ATK3	3kW, 17bit Incremental, Brake, Key, Oil-Seal
4kW	RSMH_40BQ1ASK3	4kW, 17bit Absolute, Standard, Key, Oil-Seal
	RSMH_40BQ1ATK3	4kW, 17bit Absolute, Brake, Key, Oil-Seal
	RSMH_40BR1ASK3	4kW, 17bit Incremental, Standard, Key, Oil-Seal
	RSMH_40BR1ATK3	4kW, 17bit Incremental, Brake, Key, Oil-Seal
5kW	RSMH_50BQ1ASK3	5kW, 17bit Absolute, Standard, Key, Oil-Seal
	RSMH_50BQ1ATK3	5kW, 17bit Absolute, Brake, Key, Oil-Seal
	RSMH_50BR1ASK3	5kW, 17bit Incremental, Standard, Key, Oil-Seal
	RSMH_50BR1ATK3	5kW, 17bit Incremental, Brake, Key, Oil-Seal

Memo

RS Automation Co., Ltd.

www.rsautomation.biz

38, Jinwisandan-ro, Jinwi-myeon, Pyeongtaek-si,

Gyeonggi-do, Korea, Zip code : 17709

T. +82-31-685-9300 F. +82-31-685-9500

RS Automation Global Business Support

rsagbs@rsautomation.biz

宁波信智自动化有限公司

www.rsautomation.cn

浙江省宁波市镇海区蛟川街道北欧工业园

金溪路3号A10栋2楼

总机. +86-574-2650-9821 传真. +86-574-8650-9637

RS自动化全球商户支持

nrsa@rsautomation.cn